

Mākaha Valley Flood Mitigation Study

FINAL REPORT
DECEMBER 2014

Volume I of III

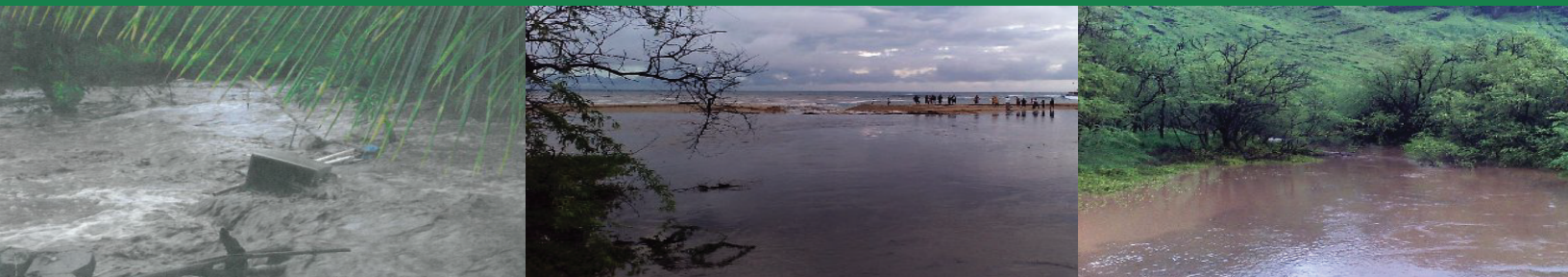

Prepared for:

**Department of Land and Natural Resources
Engineering Division**



Prepared by:

Townscape, Inc.
with the assistance of



Okahara and Associates, Inc.

*A special mahalo to community members who
contributed their time to share their mana'o.*

Photographs on the cover page (from left to right):

Flooding behind homes on Manuku Street during December 2008 storm; Sand berm break at the mouth of Mākaha Stream; Stream flow at Mākaha Stream during heavy rains (facing upstream)

Mākaha Valley Flood Mitigation Study

FINAL REPORT

DECEMBER 2014

Volume I of III



Prepared For:

**Department of Land and Natural Resources
Engineering Division**



Prepared By:

Townscape, Inc.

with the assistance of



Okahara and Associates, Inc.

This page intentionally left blank.

TABLE OF CONTENTS

LIST OF TABLES	IV
LIST OF FIGURES	IV
LIST OF ACRONYMS	V
EXECUTIVE SUMMARY	1
1. INTRODUCTION	7
2. STUDY PROCESS.....	9
3. EXISTING WATERSHED CONDITIONS	10
3.1 Physical Setting.....	10
3.2 Topography	11
3.3 Ground Cover	11
3.4 Historical Overview	11
3.5 Land Use	13
3.6 Community Overview.....	15
3.7 Flood Map.....	15
3.8 Climate Change.....	17
4. FLOOD PROBLEMS	19
5. HYDROLOGIC ANALYSIS	23
6. HYDRAULIC ANALYSIS.....	27
7. PROPOSED FLOOD MITIGATION MEASURES	32
7.1 Structural Projects.....	34
7.1.1 Project No. 01: Eku Stream Flood Channel and Off-Line Detention Basin	36
7.1.2 Project No. 02: New Eku Stream Bridge at Farrington Highway.....	40
7.1.3 Project No. 03: Noholio Road Drain Line	42
7.1.4 Project No. 04: Repair the Breach in the Mākaha Stream Berm	44
7.1.5 Project No. 05: Mākaha Stream Levee.....	47
7.1.6 Project No. 06: Kili Drive Channel	51
7.1.7 Project No. 07: Mauna ‘Olu Estates Drainage Improvements	54
7.1.8 Project No. 08: In-stream Detention Basins for Mākaha Stream	55
7.1.9 Project No. 09: Restore Mākaha Surfing Beach “Pond”	56
7.2 Nonstructural Measures	59
7.2.1 Watershed Restoration.....	59
7.2.2 Stream Channel Maintenance	61

7.2.3 Storm Drain Maintenance.....	64
7.2.4 Enforcement.....	64
7.2.5 Education on Best Management Practices for Watersheds	65
7.2.6 Drainage improvements required for future development	65
7.3 Other considerations.....	66
7.3.1 Stream erosion control	66
7.3.2 Mākaha Stream Channel.....	67
7.3.3 Farrington Highway, Replacement of Mākaha Bridges No. 3 and No.3 A.....	69
7.3.4 Mākaha West Golf Course	70
7.3.5 Farrington Highway Realignment	71
7.4 Maintenance Tasks and Costs.....	72
8. PRIORITIZATION OF STRUCTURAL PROJECTS	73
9. SUMMARY OF ENVIRONMENTAL IMPACTS	75
10. NEXT STEPS	77

LIST OF TABLES

Table 1. Mākaha Stream Tributary Points	23
Table 2. Eku Stream Tributary Points.....	23
Table 3. Full build-out Peak Flows for Mākaha Stream	25
Table 4. Full build-out Peak Flows for Eku Stream	26
Table 5. Proposed Flood Mitigation Measures.....	32
Table 6. Summary of Estimated Cost for Structural Projects	34
Table 7. Prioritization of Projects.....	73

LIST OF FIGURES

Figure 1. Project Area	6
Figure 2. Undeveloped Parcels	14
Figure 3. Flood Zones.....	16
Figure 4. Existing Drainage Systems	18
Figure 5. Storm drains clogged with rocks.....	22
Figure 6. Mākaha Stream Flood Map.....	29
Figure 7. Mākaha Stream Flood Map.....	30
Figure 8. Eku Stream Flood Map.....	31
Figure 9. Flood Zones and Proposed Projects.....	33
Figure 10. Eku Stream Flood Channel and Off-line Detention Basin Project Location.....	36
Figure 11. New Eku Stream Bridge Project Location	40
Figure 12. Noholio Street Drainage Project Location	42
Figure 13. Repair the Breach in the Mākaha Stream Project Location	44
Figure 14. Mākaha Stream Levee Project Location	47
Figure 15. Kili Drive Channel Project Location.....	51
Figure 16. Restore "Pond" Project Location	58
Figure 17. Mākaha Beach Park Master Plan (1996).....	71

Volume II

- A. Stakeholder Outreach
- B. Task 1 Report
- C. General Environmental Impact Assessment

Volume III

- A. Hydrologic and Hydraulic Report

LIST OF ACRONYMS

BMP	Best Management Practice(s)
BWS	Board of Water Supply
CDP	Census Designated Places
CDUP	Conservation District Use Permit
City	City and County of Honolulu
cfs	cubic feet per second
CFR	Code of Federal Regulations
CWA	Clean Water Act
CWRM	Commission on Water Resource Management
DLNR	Department of Land and Natural Resources
DOH	Department of Health
DOT	Department of Transportation
DPP	Department of Planning and Permitting
EA	Environmental Assessment
EIS	Environmental Impact Statement
FEMA	Federal Emergency Management Agency
HEC-RAS	Hydrologic Engineering Center River Analysis System
hrs	hours
NPDES	National Pollutant Discharge Elimination System
NRCS	Natural Resources Conservation Service
OCCL	Office of Conservation and Coastal Lands
OMPO	O‘ahu Metropolitan Planning Organization
ROH	Revised Ordinances of Honolulu
ROW	Right of Way
SCAP	Stream Channel Alteration Permit
SCD	State Civil Defense
SMA	Special Management Area
TMK	Tax Map Key
TR-55	Technical Release 55
USACE	U.S. Army Corps of Engineers
USGS	U.S. Geological Survey

Executive Summary

Introduction

This study has been prepared by Townscape, Inc. for the Department of Land and Natural Resources, in fulfillment of the requirements set forth by Act 283, Session Laws of Hawai‘i 2012. Okahara and Associates, Inc. contributed as sub-consultants for hydrology, hydraulics and civil engineering. Many members of the Mākaha community provided valuable information which has been incorporated into this study.

Over the years, Mākaha Valley has experienced numerous floods, including a 15-day rain event in November 1996 that resulted in 24 inches of rain in an area with an annual rainfall of 20 to 40 inches. A storm in December 2008¹ resulted in 12 inches of rain over the course of one day, which caused extensive flooding and significant damage to roads and homes.

Process

The study began with preliminary background research and information gathering. The study team met with community stakeholders, residents, business owners and large land owners to learn about historical flooding in the area, and also consulted with public agencies and elected officials. Hydrologic analysis was conducted to estimate the volume of water entering and passing through Mākaha during rainfall events, specifically for the 10-, 25- and 100-year storms. Hydraulic modeling was done to determine the extent of flooding for “existing conditions” and for the “full build-out²” condition. Information from the stakeholder consultation process is included in Volume II of this report; and technical details from the hydrologic and hydraulic analysis are included in Volume III of this report.

Existing Watershed Conditions

Mākaha Valley is located on the leeward (west) side of the island of O‘ahu in the State of Hawai‘i. It is approximately 5,914 acres in area and is comprised of two main watersheds, Mākaha and Kamaile‘unu. The Mākaha watershed covers about 4,659 acres—more than three-fourths of the valley—and is drained by Mākaha Stream and West Mākaha Stream. A smaller drainage basin, about 1,255 acres in size, is drained by Eku Stream (East Mākaha Stream).

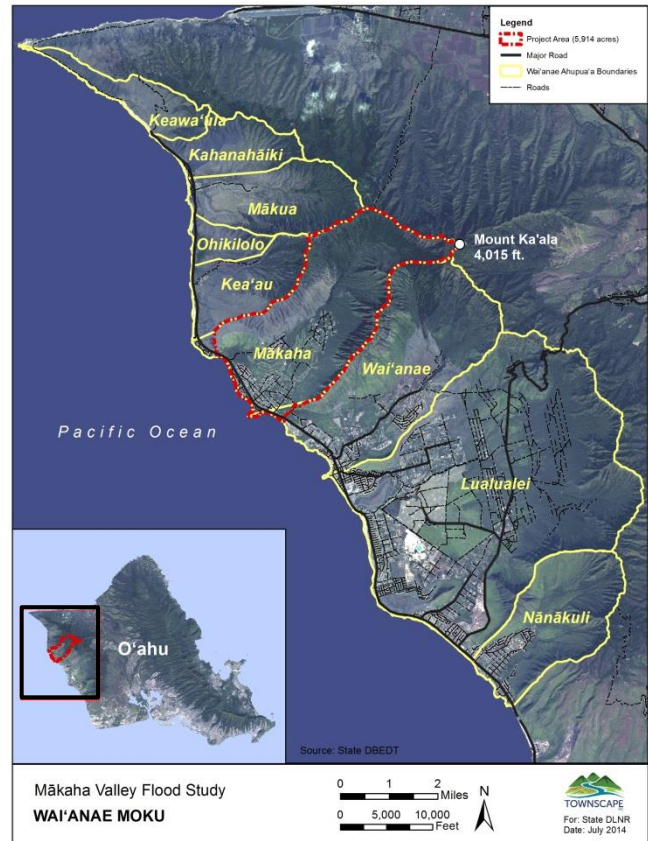

¹ Precipitation frequency estimates show that the 2008 storm was between a 100- and 200-year event for six hours.

² Full build-out assumes existing large undeveloped parcels are developed according to their city zoning designations.

Mākaha Stream and Eku Stream are the two main streams in the valley, with Mākaha being the primary stream. Mākaha Stream originates in the western slopes of the Wai‘anae mountain range and is fed by water that falls from Mount Ka‘ala. The stream flows year-round in its upper reaches and intermittently at lower elevations. Eku Stream originates approximately 9,000 feet mauka (mountainside) of Farrington Highway on the eastern side of the valley from Kamaile‘unu Ridge and flows through the Mākaha East Golf Course.

Land elevations begin at sea level and rise to the highest peak of the valley, and of O‘ahu—Mount Ka‘ala at an elevation of 4,015 feet above mean sea level. The majority of the valley walls and upper valley areas are covered with non-native grasses, shrubs, and trees. Soil types vary throughout the valley, but the steep, mountainous areas are dominated by Rock Land (rRK), Stony Land (rST), and Tropohumults-Dystrandeps (rTP) soils.

Historic land use in the valley, which included ranching, coffee, taro, and sugarcane, has significantly altered the hydrology of the valley. After Chinn Ho purchased the valley from Wai‘anae Sugar Company in the mid-1940s, he subdivided parts of the property to offer fee simple land for sale. Roads and drainage systems were not constructed to City standards and are still “privately-owned.” The privately-owned infrastructure is generally poorly maintained.

More than one-third of the valley is designated as “Urban” within the State Land Use system, while the remaining land is designated “Conservation.” The City & County of Honolulu, Board of Water Supply is the largest land owner in Mākaha. The lower Mākaha Valley consists of golf courses, residential lots and single family homes. City zoning allows for apartment, agricultural, business, country, residential, preservation and resort use. There are at least thirteen large undeveloped parcels in the valley totaling more than 462 acres that could allow for more single family homes, hotels, and duplex units.

Currently, Mākaha Valley is a rural community with a high percentage of Native Hawaiians, almost twice the percent compared to the island of O‘ahu. Median home values are generally lower by almost half the value compared to O‘ahu as a whole. The median income tends to be lower for Mākaha households compared to the median household income for the island, and the percentage of people living below poverty level is higher when compared to O‘ahu.

The Flood Insurance Rate Map (FIRM) is the official map from the Federal Emergency Management Agency (FEMA) that delineates the special flood hazard areas in a community. At the time of this study, the latest FIRM for the City & County of Honolulu was published in 2011. Revised flood maps for the City & County of Honolulu were published by FEMA in November 2014. However, there were no changes in flood risk areas for Mākaha Valley. Mākaha Valley has high risk areas consisting of Zones AE and VE. These zones are located in the Special Flood Hazard Area (SFHA) and are subject to inundation by the 1-percent annual chance flood (often referred to as the 100-year flood). A 1-percent annual chance flood means that there is a one percent chance that flood will occur in any given year. A 1-percent annual chance flood could occur two or three years consecutively; this designation does not mean that this major flood only occurs once in every hundred years.

Impacts from climate change will contribute to greater vulnerability of Hawai‘i communities, especially those located along the coast. Even without future development in Mākaha adding to flooding conditions, flooding is anticipated to worsen due to climate change.

Flood Problems

Mākaha Valley lacks an overall interconnected drainage system. Rather, the drainage system in Mākaha is the result of “piecemeal” development without a master plan for the valley. A series of ditches, earthen berms, swales, catch basins, culverts, and underground pipes make up the drainage system for the developed areas of the valley. The majority of the runoff from these drainage systems is conveyed towards Mākaha Stream and some towards Eku Stream, but the stream capacities have not been improved. As a result, the streams overtop their banks during storm events and inundate surrounding areas where many homes are located. Most of the flood problems occur in the lower areas of the valley within the floodplain, including near Mākaha Stream, Eku Stream, and along Kili Drive, Mākaha Valley Road, Noholio Road and Lahaina Street. Some of the major flood problems and issues in Mākaha Valley are:

- Altered stream alignments
- Restrictions at the stream mouth contributing to flooding of properties near the mouth of Mākaha and Eku Streams
- “Unimproved” stream channel resulting in flooding of properties adjacent to Eku Stream
- Damaged drainage systems
- Lack of drainage infrastructure
- Clogged drainage infrastructure
- Lack of maintenance program

Hydrologic Analysis

Hydrologic analysis, using the Natural Resources Conservation Service (NRCS) Technical Release 55 (TR-55) method, determined the peak flows of Mākaha and Eku Streams. The calculated peak flows for a 10-, 25-, and 100-year storm for Mākaha Stream were 6,045 cubic feet per second (cfs), 8,166 cfs, and 11,413 cfs respectively. The calculated peak flows for a 10-, 25-, and 100-year storm for Eku Stream were 2,853 cfs, 3,792 cfs, and 5,201 cfs respectively.

Hydraulic Analysis

Full build-out peak flows from WinTR-55³ were inputted into the U.S. Army Corps of Engineers Hydrologic Engineering Center River Analysis System (HEC-RAS) computer model to analyze the extent of inundated areas from Mākaha and Eku Streams for the 10-, 25-, and 100-year storms. Analysis showed that Eku Stream is well defined and contained until approximately 3,800 feet upstream of the mouth. For Eku Stream, the flood limits for the 10-, 25- and 100-year storms in the upper elevations differ only slightly because of the deeper and more defined stream cross sections. As Eku Stream reaches the lower elevations, the flood limits of the 10-, 25-, and 100-year storms differ significantly due to the very flat terrain found in most of the lower areas. For Mākaha Stream, the banks are more defined and therefore the flood limits differ only slightly for the 10-, 25-, and 100-year storms. The flood

³ Computer software program that applies the TR-55 model

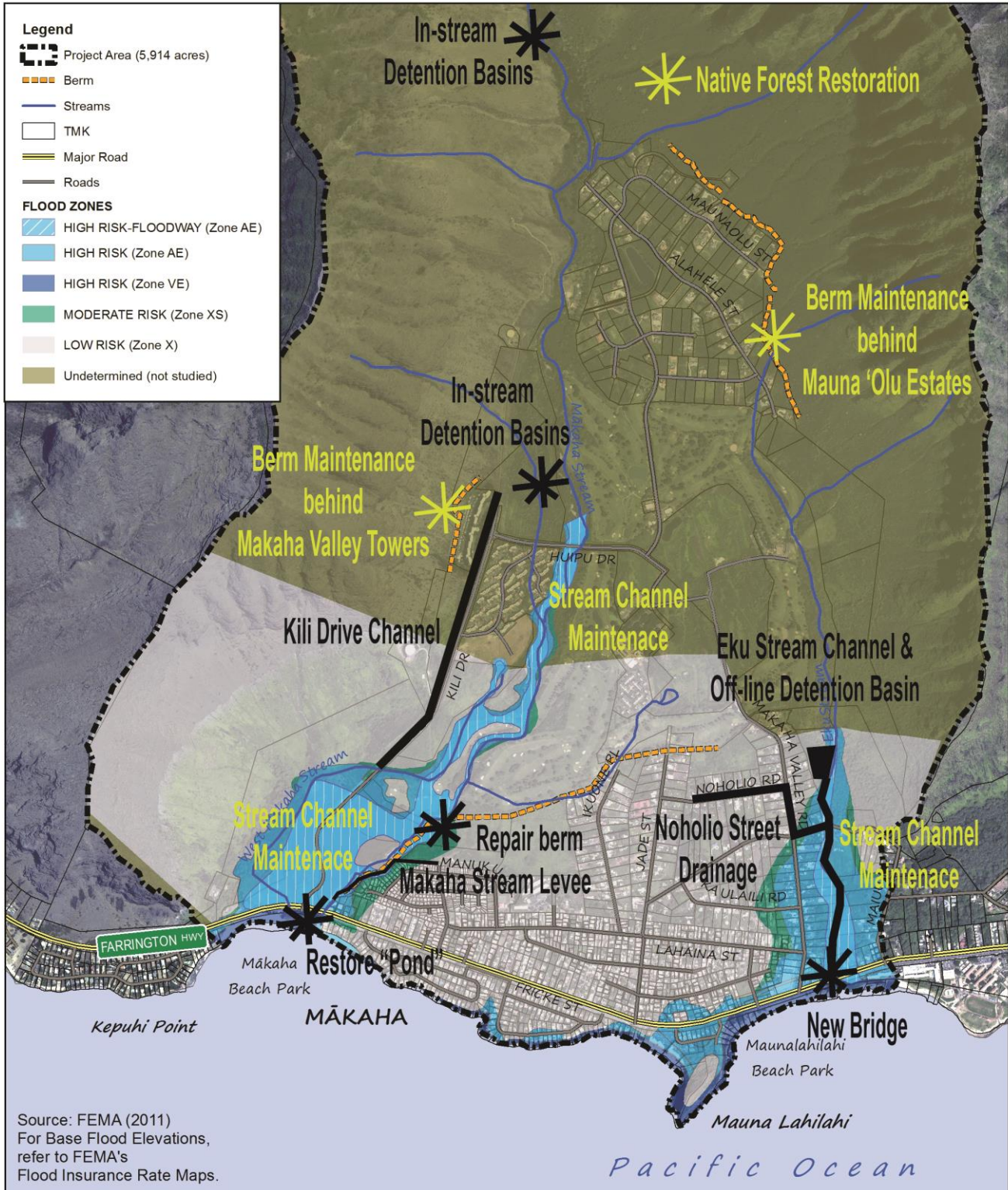

Source: FEMA (2011)
 For Base Flood Elevations,
 refer to FEMA's
 Flood Insurance Rate Maps.

Mākaha Valley Flood Study
FLOOD ZONES AND PROPOSED PROJECTS



elevations range from two to seven feet within the well-defined streambed of Eku Stream, while the flood elevations in the lower areas of Eku Stream can range from zero to three feet. Flood depths for Mākaha Stream range from five to over ten feet within the streambed and can range from zero to four feet in the Mākaha Stream floodplain.

Proposed Flood Mitigation Measures

Based on hydrologic and hydraulic analysis of the watersheds and discussions with community members, the structural projects and nonstructural programs recommended for Mākaha Valley are:

Structural Projects	Nonstructural Programs
<ol style="list-style-type: none"> 1. Eku Stream Channel and Off-line Detention Basin 2. New Eku Stream Bridge at Farrington Highway 3. Noholio Road Drain Line 4. Repair the breach in the Mākaha Stream berm 5. Mākaha Stream Levee 6. Kili Drive Channel 7. Mauna ‘Olu Estates Drainage Improvements 8. In-stream Detention Basins for Mākaha Stream 9. Restore Mākaha Surfing Beach “Pond” 	<ol style="list-style-type: none"> 1. Forest Restoration 2. Stream Channel Maintenance 3. Storm Drain Maintenance 4. Enforcement of existing legislation 5. Education on Best Management Practices for Watersheds 6. Drainage improvements required for future development

Note: Projects are not numbered in order of importance.

Below are estimated costs for structural projects. Generally, the projects are “stand-alone” projects, which mean that the recommended project can be constructed independently of the other projects. Projects are not numbered in order of importance.

Project No.	Mitigation Measure	Total Estimated Cost
1	Eku Stream Channel and Off-line Detention Basin	\$27,767,000 - \$34,767,000
2	New Eku Stream Bridge at Farrington Highway	\$12,000,000 - \$19,000,000
3	Noholio Road Drain Line	\$1,700,000 - \$3,300,000
4	Repair the breach in the Mākaha Stream berm	\$300,000 - \$450,000
5	Mākaha Stream Levee	\$17,021,000 - \$24,021,000
6	Kili Drive Channel	\$12,000,000 - \$19,000,000
7	Mauna ‘Olu Estates Drainage Improvements	To be determined
8	In-stream Detention Basins for Mākaha Stream	\$13,000,000 - \$18,000,000
9	Restore Mākaha Surfing Beach “Pond”	To be determined
TOTAL ESTIMATED COST		\$83.5 - \$118.1 million¹

¹The total estimated cost does not include Project No. 4 “Repair the breach in the Mākaha Stream berm” as it would not be necessary with the construction of Project No. 5: “Mākaha Stream Levee.”

However, recognizing that these high costs will be difficult to fund, the project team also developed a set of alternative costs that assume the use of earthen berms and channels, instead of reinforced concrete.

Project No.	Mitigation Measure (Alternative Method)	Total Estimated Cost
1	Ekū Stream Channel with erosion control matting	\$10,000,000 - \$11,000,000
5	Repair existing Mākaha Stream berm	\$500,000 - \$600,000
6	Kili Drive Channel with erosion control matting	\$1,300,000 - \$1,500,000
TOTAL ESTIMATED COST WITH ALTERNATIVE METHODS		\$38.8 - \$ 53.9 million¹

¹The total estimated cost replaces the estimated cost for Projects No. 1, 5 and 6 with estimated cost for the alternative method; and includes the cost for Project No. 4 "Repair the breach in the Mākaha Stream berm."

Prioritization of Structural Projects

Projects were grouped based on feasibility of implementation. Projects with relatively low cost and high implementation likelihood, or with large benefits relative to their cost were categorized as Group 1. More complex and costly projects were included in Group 2. Additional projects with high initial cost relative to their benefits were listed in Group 3.

Group 1	Group 2	Group 3
<ul style="list-style-type: none"> • Repair the breach in the Mākaha Stream berm • Restore Mākaha Surfing Beach "Pond" • Ekū Stream Channel and Off-line Detention Basin 	<ul style="list-style-type: none"> • Mākaha Stream Levee • New Ekū Stream Bridge at Farrington Highway 	<ul style="list-style-type: none"> • Kili Drive Channel • In-stream Detention Basins for Mākaha Stream • Noholio Road Drain Line

Summary of Environmental Impacts

No significant environmental impacts are anticipated from the proposed projects. Proposed projects will benefit public health and safety in terms of mitigating flood hazards, but may accelerate the velocity of runoff and reduce sedimentation of floodplain areas before discharging into the ocean. A more in-depth analysis of archaeological sites within the area may be required. Permits and approvals including a Grading permit, Special Management Area permit, Environmental Assessment or Environmental Impact Statement, Stream Channel Alteration Permit, National Pollutant Discharge Elimination System permit, Water Quality Certification, and Section 404 permit may be needed.

Next Steps

Significant funding will be needed to implement the proposed flood mitigation projects. A key strategy will be to secure funding for design and construction of projects incrementally. Identification of an entity that will assume ownership and/or perpetual maintenance of some of the improvements will be a challenge. The majority of the structural projects are located on privately-owned property.

1. Introduction

This study has been prepared by Townscape, Inc. for the Department of Land and Natural Resources (DLNR), in fulfillment of the requirements set forth by Act 283, Session Laws of Hawai'i 2012. Okahara and Associates, Inc. contributed as sub-consultants for hydrology, hydraulics and civil engineering. The requirements of the Act include the preparation of a flood study for Mākaha Valley, an investigation of all potential funding sources to finance flood mitigation projects, and provision of recommendations on improvements or repairs to mitigate flooding.

Over the years, Mākaha Valley has experienced numerous floods, including a 15-day rain event in November 1996 that resulted in 24 inches of rain in an area with an annual rainfall of 20 to 40 inches. A storm in December 2008 resulted in 12 inches of rain over the course of one day, which caused extensive flooding and significant damage to roads and homes.

Flooding in Mākaha Valley not only results in physical damage such as flooded homes and roads, but it also affects the community socially and economically. These consequences include economic impacts, impacts on psychological and physical health, household disruption, evacuation, displacement and temporary accommodation.

The economic impacts of floods include the cost of damage to property as well as to roads and other infrastructure. Residents incur the cost of cleaning up after the storm and possibly the cost of temporary relocation. Residents living in floodplain areas already have to incur higher costs of purchasing flood insurance. Flooding on roads, particularly on Farrington Highway and heavily used roads such as Kili Drive and Mākaha Valley Road can cause disruption to many residents who are unable to travel to and from their homes. Farrington Highway, which serves as the main road along the coast, is vulnerable to inundation by both riverine flooding and storm surge. If the highway is flooded, residents in Mākaha Valley and beyond could potentially be isolated from the rest of the island.

This report discusses the study process; provides an overview of existing watershed conditions; summarizes the flood problem areas; provides the hydrologic and hydraulic analysis; presents recommended flood mitigation projects and measures; and evaluates the effectiveness of each project to mitigate flooding. This report also provides a summary of environmental impacts of the proposed flood mitigation projects and concludes with future actions needed for implementation.

This report provides a succinct description of this flood study. Technical details have been documented in a separate volume of appendices.



*Car overturned in upper parking lot of Mākaha Valley
Towers after storm in November 1996
Photo Credit: Star-Bulletin*

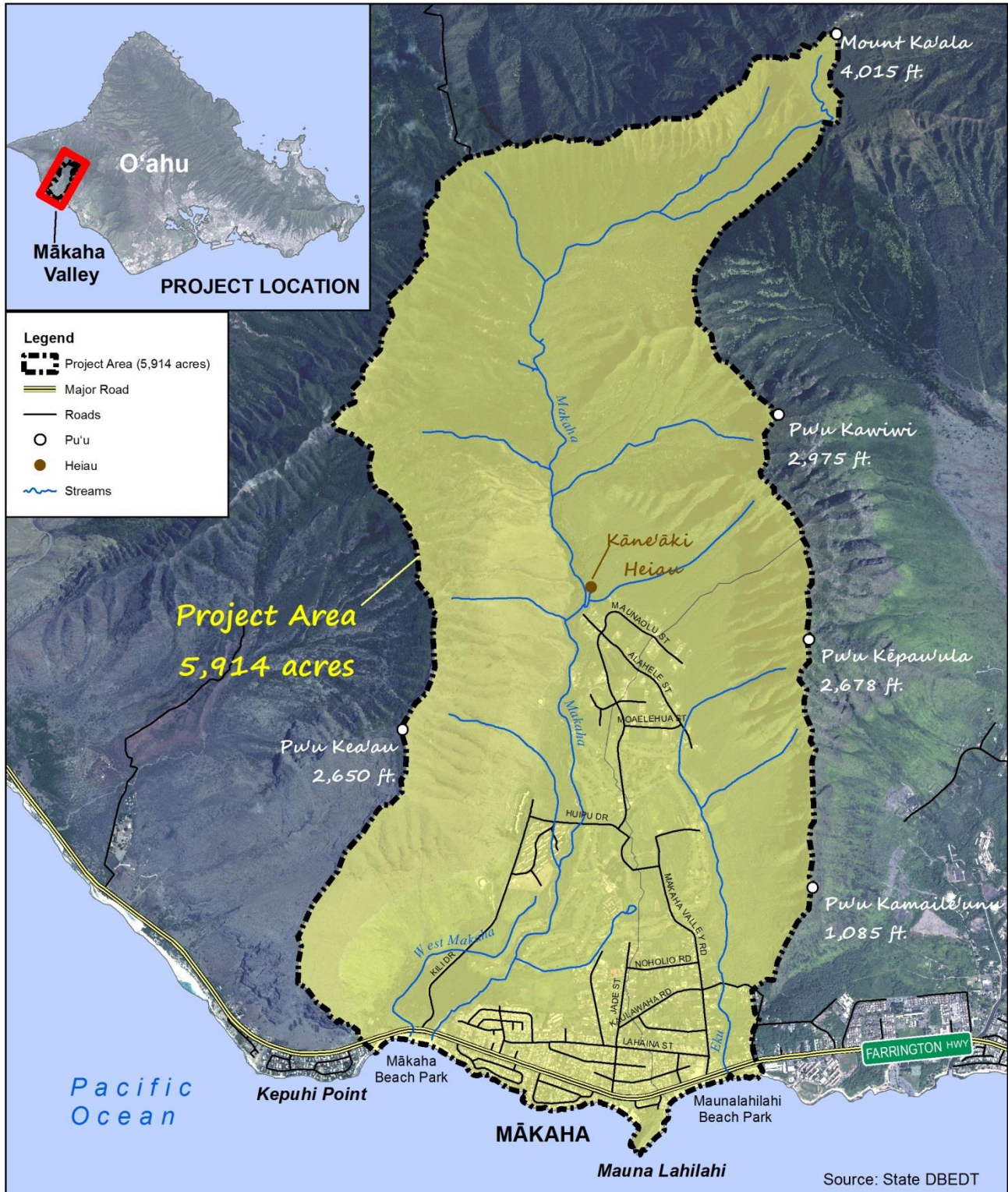

Mākaha Valley Flood Study

Figure 1. Project Area

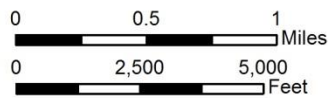

For: State DLNR
Date: July 2014

2. Study Process

The study began with preliminary background research and information gathering. The study team met with community stakeholders, residents, and government personnel to learn about historical flooding in the area. It was important for the team to understand some of the flooding issues from the perspective of those who have experienced the flooding problems “first-hand” and who throughout the years have observed the hydrologic changes in the valley due to land use changes, development, and urbanization. The project team also met with business owners and large land owners, public agencies, and elected officials. Meetings included one-on-one meetings, small group meetings, site visits to problem areas with stakeholders, and community meetings to gather input and to share findings from the study. Three community meetings were held for this study. Information from the stakeholder consultation process is included in Volume II of this report.

Hydrologic analysis was conducted to estimate the volume of water entering and passing through Mākaha during a rainfall event, specifically for the 10-, 25- and 100-year storms. Hydraulic modeling was done to determine the extent of flooding for “existing conditions” and for the “full build-out⁵” condition. Community stakeholders, business owners, large land owners, and public agencies were consulted again after the project team developed concepts for preliminary flood mitigation projects.



First of three community meetings held at Wai‘anae District Park

⁵ Full build-out assumes existing large undeveloped parcels are developed according to their city zoning designations.

3. Existing Watershed Conditions

3.1 Physical Setting

Mākaha Valley is located on the leeward (west) side of the island of O‘ahu in the State of Hawai‘i. One of the nine valleys on the leeward coast, Mākaha Valley is situated between Wai‘anae to its south and Kea‘au to its north. The valley is approximately five miles long and about two miles wide.

Mākaha Valley is approximately 5,914 acres in area and is comprised of two main watersheds, Mākaha and Kamaile‘unu. The Mākaha watershed covers about 4,659 acres—more than three-fourths of the valley—and is drained by Mākaha Stream and West Mākaha Stream. A smaller drainage basin, about 1,255 acres in size, is drained by Eku Stream (East Mākaha Stream).

Mākaha Stream and Eku Stream are the two main streams in the valley, with Mākaha as the primary stream. Mākaha Stream originates in the western slopes of the Wai‘anae mountain range and is fed by water that falls from Mount Ka‘ala. It flows southwesterly and terminates behind a large sand berm at Mākaha Beach Park. The stream flows year-round in its upper reaches and intermittently at lower elevations.

Eku Stream originates approximately 9,000 feet mauka of Farrington Highway on the eastern side of the valley from Kamaile‘unu Ridge and flows through the Mākaha East Golf Course. The stream is well defined and contained until approximately 3,800 feet upstream of the stream mouth.

Hydrologic information is available from the two U.S. Geological Survey (USGS) stream gages (USGS Station Number 16211600 and 16211700) and the USGS rainfall gage (State Key number 842.1), all of which are located on Mākaha Stream. The stream gages provide data on annual peak streamflow⁶, while the rainfall gage provides data on daily precipitation in inches.

The climate in Mākaha is generally reflective of conditions for leeward areas in Hawai‘i, with rainfall ranging from about 25 inches per year in the coastal areas to about 80 inches per year at the highest elevations near Mount Ka‘ala. The two seasons are distinguished by cooler temperatures and wet conditions during the winter months, generally between October and April, and drier and warmer conditions with northeasterly trade winds during the summer months. The leeward side is typically drier than the windward (east) side of O‘ahu. Most of the rainfall of the leeward areas is from major storms associated with the passage of a cold front or a Kona storm. These storms are more common in the winter and develop from the northwest and slowly move eastward, bringing extensive periods of rain to the leeward areas that may last for a week or more.

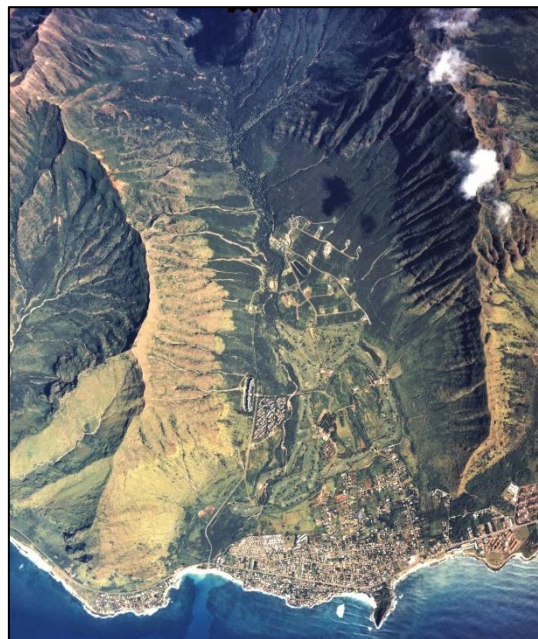

Aerial view of Mākaha Valley (1997)

⁶ USGS Gage No. 16211700 was discontinued in 2004 due to lack of funding.

3.2 Topography

Land elevations begin at sea level and rise to the highest peak of the valley, and of O‘ahu—Mount Ka‘ala at an elevation of 4,015 feet above mean sea level. The valley is defined by steep, nearly vertical ridges—with slopes greater than 200 percent—along both sides of the valley. From sea level to about 2.5 miles inland, the valley floor gradually increases to a 15 percent gradient and an elevation of about 600 feet. From there, the slope gradually becomes steeper until it reaches the top of the valley which is slightly less than five miles inland from the coast. The width of the valley floor varies from less than half a mile wide near Kāne‘ākī Heiau, to nearly two miles wide near the coast.

3.3 Ground Cover

The majority of the valley walls and upper valley areas are covered with non-native grasses, shrubs, and trees. Invasive species such as coffee and strawberry guava are found throughout the forested areas. Native ‘ōhi‘a trees and tropical uluhe fern shrubland cover a small portion of the upper valley near Mount Ka‘ala. Kiawe forest and shrubland covers a significant part of the lower and mid-valley. The ridges are generally rocky outcrops with minimal vegetation cover. The majority of the streambeds, particularly from mid-valley to the ocean, are overgrown with non-native vegetation.

Soils vary throughout the valley, but the steep, mountainous areas are dominated by Rock Land (rRK), Stony Land (rST), and Tropohumults-Dystrandeps (rTP) soils. Soils are also classified into hydrologic soil groups based on runoff potential and infiltration rates. There are four groups (A-D): Group A with the lowest runoff potential when thoroughly wet to Group D with the highest runoff potential when thoroughly wet. The majority of the soils near the streams are classified as Group B.

3.4 Historical Overview

Mākaha Valley is one of the nine ahupua‘a within the moku of Wai‘anae on the island of O‘ahu. Mākaha had the second most abundant water sources after Wai‘anae Valley on the Leeward Coast. Therefore, Mākaha also supported the next largest population after Wai‘anae prior to European contact. Unlike other ahupua‘a, settlement in Mākaha was primarily in the mid- to upper-valley because of the abundant and easily accessible water sources in the valley. Mākaha Valley was a self-sufficient Hawaiian community, where Mākaha Stream flowed in the upper valley. Some researchers believe that the stream flowed continuously to the sea. The lower valley supported extensive dryland agricultural crops and some permanent house sites that were used in the early A.D. 1100s to 1300s. Irrigated fields filled the middle of the valley towards the upper valley. Lo‘i were built by the 1500s in the upper valley along with permanent houses. By the 1600s, the valley



Present-day Kāne‘ākī Heiau restored

experienced population growth. Irrigated taro fields were built on stream flats. The lo'i were extended into the lower valley in the 1700s.

Large sandalwood forests filled the valleys along the Wai'anae Coast. By 1811, Hawaiian chiefs were trading sandalwood in exchange for luxury goods from the western sailors, who were then selling the sandalwood in China. Hawaiian commoners were ordered to cut sandalwood for the chiefs, which resulted in leaving taro patches unattended.

During the Great Mahele, very few commoners claimed land in Mākaha. The High Chief Abner Pahi acquired title to about 5,000 acres of land, which was almost the entire valley. When High Chief Pahi died in 1855, his Mākaha lands were sold to the James Robinson and Company for \$5,000 in gold. Later in 1862, Owen Jones Holt, one of the partners in the company, bought out the shares of the others. Until the late 19th century, Mākaha Valley was used as a ranch for horses, cattle, sheep, chickens, turkeys, and pigs. During that time, the Mākaha Coffee Company purchased approximately 125 acres in upper Mākaha Valley for coffee cultivation.

In the early 1900s, the Holts began selling off land in Mākaha. The Wai'anae Sugar Company slowly made its way into the valley and by 1923, almost all of lower Mākaha Valley was used for sugar cane cultivation. The sugar plantation demanded large volumes of water, but there was limited water supply in the arid Wai'anae Coast. The lack of water resources contributed to the low profitability and limited expansion of the plantation. American Factors, Limited (Amfac, Inc.) purchased the Wai'anae Sugar Company in 1931 and initiated a geologic study of the ground water in the mountain ridges in the back of Mākaha and Wai'anae Valleys. The study showed that it was possible to dig a tunnel into the base of the mountains to mine groundwater. However, work on the tunnel did not commence until after 1945 due to World War II. The completed tunnel was 4,200 feet long and had a daily flow of 700,000 gallons of water. The water was mostly used to irrigate the sugar, but not long after, Wai'anae Plantation became available for purchase. Capital Investment Company, owned by the Chinese investor Chinn Ho, purchased the land including the water rights for \$1.25 million, and soon offered fee simple lots for sale. His vision for Mākaha Valley was the "next Waikīkī."

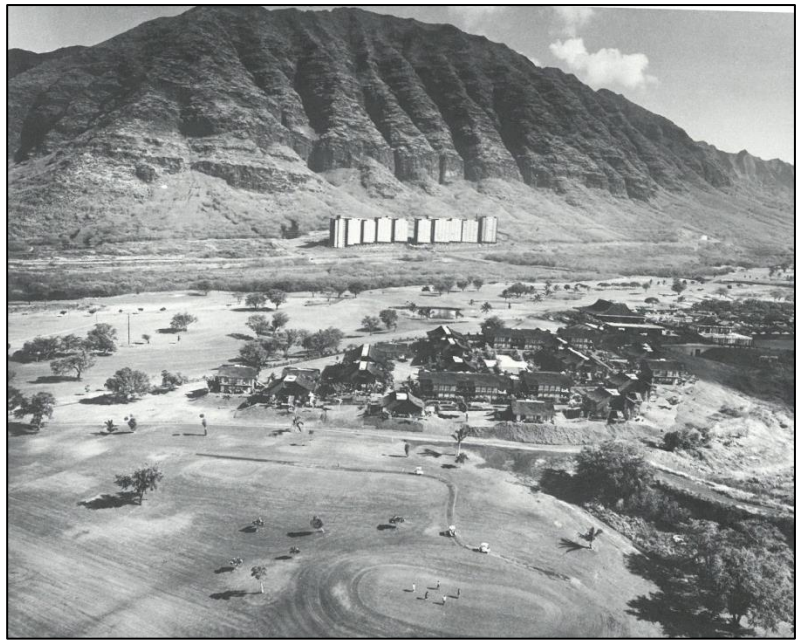

Chinn Ho's Mākaha Inn and two championship golf courses
Photo Credit: Historic Wai'anae (1973)

3.5 Land Use

More than one-third of the valley is designated as “Urban” within the State Land Use system, while the remaining area is designated as “Conservation.” The urban designation extends at least half way into the valley and is the largest urban land designation along the Wai‘anae coast—allowing for concentrations of development and infrastructure. Storm water runoff from developed areas compared to undeveloped areas is generally greater since development results in more impervious surfaces such as roads and roofs and less water infiltrates into the ground.

The State does not own any land in Mākaha with the exception of the summit of the valley at Ka‘ala Natural Area Reserve (less than 2 percent of the total valley). The City & County of Honolulu (City), Board of Water Supply (BWS) is the largest land owner in Mākaha—owning the majority of the forested lands designated as “Conservation” in the back of the valley and along the valley walls surrounding Mākaha, totaling approximately 4,015 acres.

For the land designated as “Urban”, city zoning allows for apartment, agricultural, business, country, residential, preservation and resort use. There are at least thirteen large undeveloped parcels in the valley totaling more than 462 acres that could be developed for single family homes, hotels, duplex units and recreational facilities. The majority of the lower Mākaha Valley consists of residential lots and single family homes.

The lower Mākaha Valley lots were originally subdivided by Chinn Ho when he purchased the property and sought to attract new residents by offering affordable fee simple land. Parts of Mākaha Valley were subdivided and sold off as beach lots, house lots, and shopping centers. While Chinn Ho later built the former Mākaha Valley Inn, a 200-room luxury hotel, golf courses, restaurant, tennis courts, and other golf facilities in Mākaha Valley, private developers built the majority of the roads within the subdivisions. Most of the privately built roads were not constructed to City standards, and therefore the ownership of the majority of these roads and drainage systems remains private or “various.” These privately owned roads and drainage systems are mostly mauka of Lahaina Street, including Kili Drive and Mākaha Valley Road. As a result of the different ownerships, there are inconsistent levels of maintenance and repair.



Homes located at the base of steep valley walls

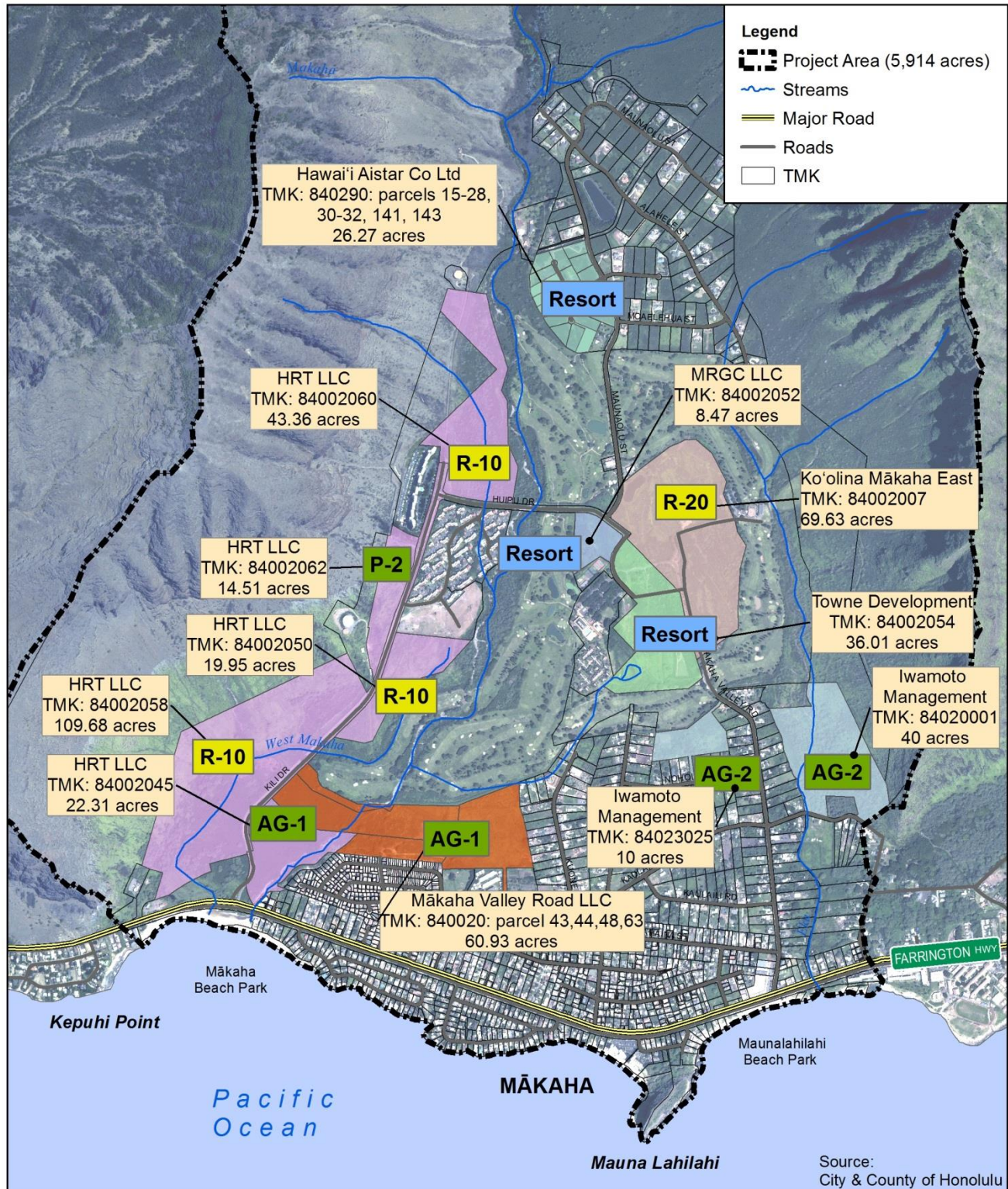

Mākaha Valley Flood Study

Figure 2. Undeveloped Parcels

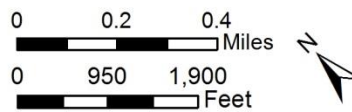

3.6 Community Overview

Mākaha Valley is a rural community with a high percentage of Native Hawaiians, almost twice the percent compared to the island of O‘ahu. Median home values are generally lower by almost half the value compared to O‘ahu as a whole. The median income tends to be lower for Mākaha households compared to the median household income for the island, and the percentage of people living below poverty level is higher when compared to O‘ahu.

There are two Census Designated Places (CDP) that make up the Mākaha Valley area, one that covers the mid- to upper valley mauka of the golf courses and the other includes the lower areas makai of the golf courses. Based on the U.S. Census data from 2010, the majority of residents live in the lower section of the valley, making up 86 percent of the valley’s total estimated population of 9,619. Mākaha Valley’s population represents about one percent of O‘ahu’s overall population. The median age for Mākaha’s population is about 33 years old, slightly younger than the median age of 38 for O‘ahu.

A higher concentration of Native Hawaiian families resides in the lower sections of the valley, while there is generally a higher concentration of Caucasian families living in the upper sections. In the 2010 U.S. Census, 60 percent in the lower sections of the valley identified themselves as at least partly Native Hawaiian or other Pacific Islander compared to only 47 percent in the upper valley. Generally, recently constructed and higher value homes are located in the mid and upper sections of the valley than the lower area.

3.7 Flood Map

The Flood Insurance Rate Map (FIRM) is the official map from the Federal Emergency Management Agency (FEMA) that delineates the special flood hazard areas in a community. At the time of this study, the latest FIRM for the City & County of Honolulu was published in 2011. FEMA published revised flood maps for the City & County of Honolulu that took effect on November 5, 2014. However, there were no changes for Mākaha Valley.

Flood zones for the FIRMs are classified based on varying levels of flood risk. Mākaha Valley has high risk areas consisting of Zones AE and VE (**Figure 3**). The moderate risk areas consist of Zone XS and the low risk areas consist of Zone X. These zones are defined by FEMA as follows:

- **Zone AE:** High Risk. Areas subject to flooding by the 1-percent annual chance flood event determined by detailed methods. Base flood elevations are shown.
- **Zone VE:** High Risk. Areas subject to flooding by the 1-percent annual chance flood event with additional hazards due to storm-induced velocity wave action. Base flood elevations derived from detailed hydraulic analyses are shown.
- **Zone XS:** Moderate Risk. Areas within the 0.2% annual chance flood. No base flood elevations or depths are shown within this zone.
- **Zone X:** Low Risk. Areas determined to be outside the 0.2% annual chance floodplain. No base flood elevations or depths are shown within this zone.

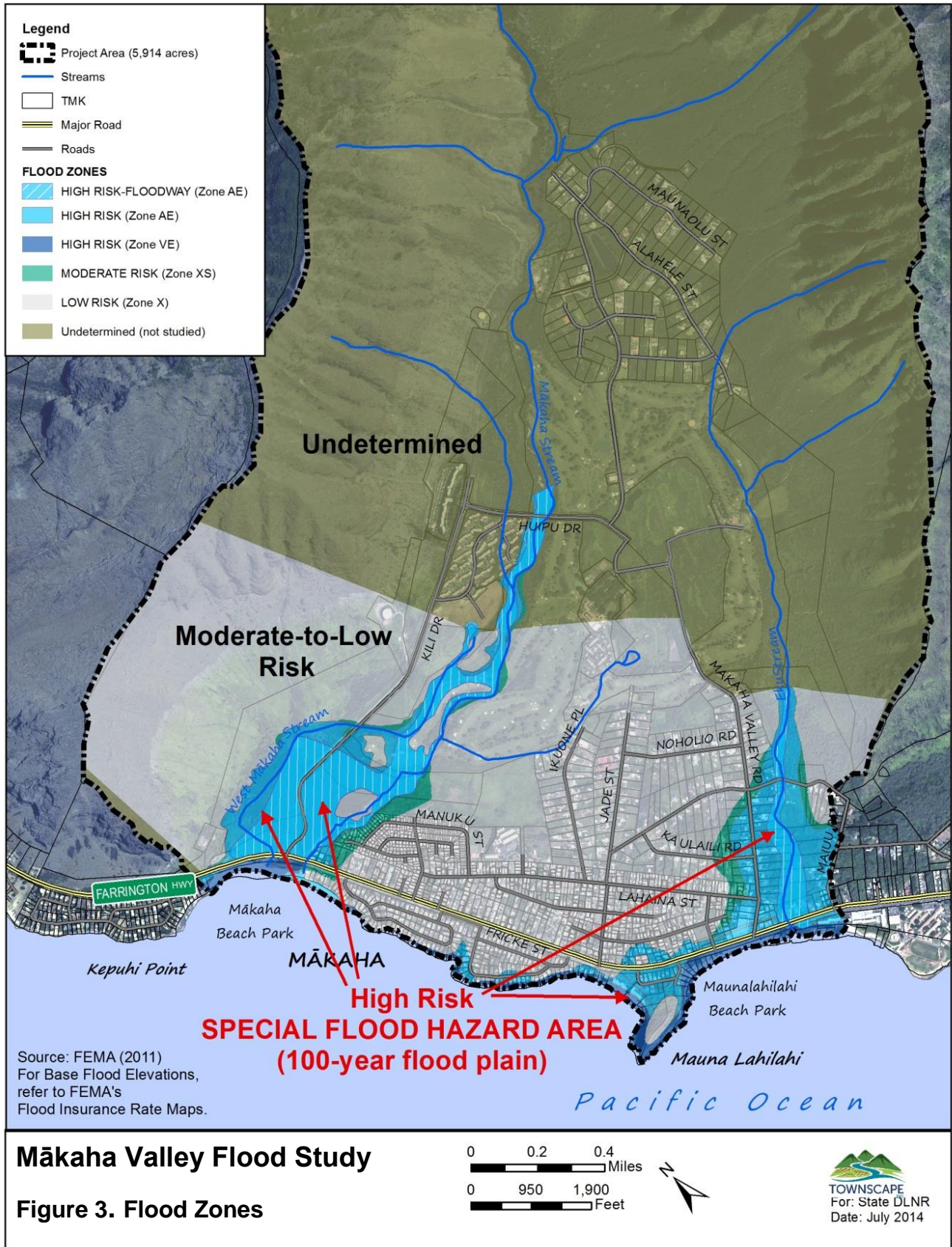

- **Floodway:** The floodway is the channel of a stream plus any adjacent areas that must be kept free of encroachment so that the 1-percent annual chance flood can be carried without substantial increases in flood height.
- **Zone D:** Areas that have not been studied where flood hazards are undetermined but possible.

Both Zones AE and VE are located in the Special Flood Hazard Area (SFHA) and are subject to inundation by the 1-percent annual chance flood (often referred to as the 100-year flood). A 1-percent annual chance flood means that there is a one percent chance that flood will occur in any given year. A 1-percent annual chance flood could occur two or three years consecutively; this designation does not mean that this level flood only occurs once in every hundred years.

There are more than 80 properties near Eku Stream, from Farrington Highway to Kaulawaha Road, that are affected by the 100-year flood. On the other hand, the majority of the parcels that are affected by the 100-year flood near Mākaha Stream are undeveloped. Properties along the coast, including Farrington Highway, are subject to inundation and erosion as a result of coastal flooding.

A significant acreage of the valley has not been studied, and is classified as “Undetermined.” While these areas have not been studied, there may still be flood risk.

3.8 Climate Change

Scientists have already documented some of the impacts from climate change for Hawai‘i including: an increase in air temperature, decrease in rainfall and stream flow, increase in rain intensity and an increase in sea level and sea surface temperatures. Major consequences of climate change that could intensify flooding issues are an increase in frequency and intensity of major storms and accelerated sea level rise. Global mean sea level is predicted to rise one foot in the next 40 years and up to three feet over the next century.

Impacts from climate change will contribute to greater vulnerability of communities, particularly those living along the coast. Even without future development in Mākaha contributing to the flooding conditions, the flooding is anticipated to worsen due to climate change.

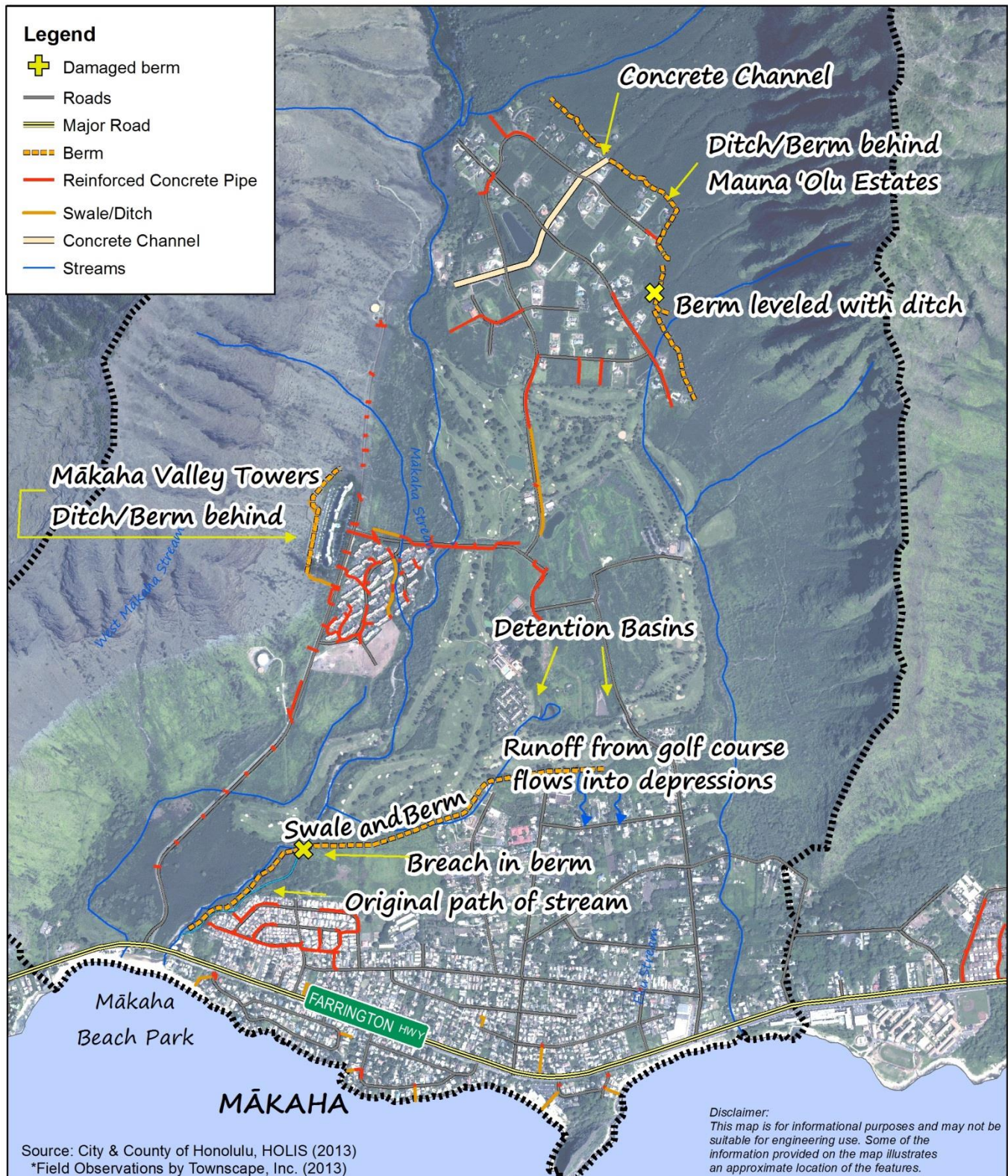

Mākaha Valley Flood Study

Figure 4. Existing Drainage Systems

0 0.15 0.3 Miles

0 750 1,500 Feet



TOWNSCAPE
For: State DLNR
Date: July 2014

4. Flood Problems

Mākaha Valley lacks an overall interconnected drainage system. Rather, the drainage system in Mākaha is the result of “piecemeal” development without a master plan for the valley. A series of ditches, earthen berms, swales, catch basins, culverts, and underground pipes make up the drainage system for the valley (**Figure 4**). The majority of the runoff from these drainage systems is conveyed towards Mākaha Stream and some towards Eku Stream, but the stream capacities have not been improved. As a result, the streams overtop their banks during large storm events and inundate surrounding areas where many of the homes are located. Some homes and apartments are located at the base of the mountains, close to very steep and almost vertical cliffs. Waterfalls cascade from the valley walls during large storms, similar to “streams” forming on the side of the mountains.



View from Mākaha Valley Plantation of waterfalls cascading from valley walls

Photo Credit: Mākaha Valley Plantation

Below is a summary of the impacts of past large storms that have brought heavy rain and flooding for Mākaha Valley:

- Storm water runoff in the upper areas of the valley is rapid because of the predominance of non-native vegetation like strawberry guava. Flood flows in the main channel of Mākaha Stream tear out large sections of stream bank and carry silt, boulders and forest debris downstream.
- Sections of Mākaha Stream become blocked by debris, such as tree limbs and boulders, causing localized flooding and erosion of areas of the forest near the stream.
- Waterfalls form along the steep walls of the valley. On the east side of the valley, the waterfalls overwhelm the Mauna ‘Olu Estates ditch/berm system and roads and homes are flooded. On the west side of the valley, the waterfalls overwhelm the Mākaha Towers ditch/berm system and the parking lot and ground floor areas are flooded.

- The flood flows on the west side of the valley continue through the Mākaha Valley Towers property and flow across Kili Drive into the Mākaha Valley Plantation complex, flooding roads, parking lots and ground floor units. Flood flows continue down Kili Drive toward Farrington Highway and Mākaha Beach.
- Localized flooding occurs throughout the middle of the valley when drainage swales, channels and culverts are overwhelmed by storm water runoff.
- On the east side of the valley, the lower reaches of Eku Stream quickly fill and then overflow into nearby homes. Several blockages of the stream channel cause even more homes to be flooded. The Eku Stream Bridge at Farrington Highway is blocked by debris, increasing the severity of flooding. In all, 80 or more homes experience significant flood damage from Eku Stream.
- Natural drainage swales in the lower section of the valley are overwhelmed by large volumes of storm water runoff and some 50 to 100 homes in this area are damaged by these localized flood flows.
- The deeply incised channel of Mākaha Stream contains the flood flows of about 8000 cubic feet per second (cfs) until the vicinity of the Huipu Drive Bridge. Where the stream channel begins to widen, the flood waters overtop the stream channel and cause flooding of the golf course and lands to the west of the stream. In the past, an earthen berm that was constructed to protect properties to the east of the stream failed in several places, and flood waters now flow through homes on Water Street and Manuku Street and then on to Farrington Highway and Mākaha Beach.
- Homes located along Farrington Highway near Mākaha Beach are flooded. Farrington Highway is flooded to a depth of three feet and is impassable for several hours. The flood flows, blocked by the large beach berm, run towards the West Mākaha Stream outlet, then flow seawards, break through the smaller beach berm and carry mud, litter, debris, trees, dead animals and trash onto Mākaha Beach and into the nearshore waters. Much of the sand in this section of the beach is torn away by the flood waters.
- Polluted storm runoff degrades the quality of nearshore waters and impacts ocean biota.



Debris along Eku Stream after December 2008 storm



Debris within Eku Stream after December 2008 storm

Most of the flood problems were identified in the lower areas of the valley within the floodplain, including near Mākaha Stream, Eku Stream, and along Kili Drive, Mākaha Valley Road, Noholio Road and Lahaina Street.

Some of the major flood problems and issues in Mākaha Valley are:

- Altered stream alignments
- Restrictions at the stream mouth contributing to flooding of properties near the mouth of Mākaha and Eku Streams
- “Unimproved” stream channel resulting in flooding of properties adjacent to Eku Stream
- Damaged drainage systems
- Lack of drainage infrastructure
- Clogged drainage infrastructure
- Lack of maintenance program



Damages to Kili Drive after January 2011 storm

Historic land use in the valley, including uses from the plantation days, significantly altered the hydrology of the valley. The topography was changed in order to divert water for irrigation purposes. A number of these features are still in existence. In addition, the original stream alignment for Mākaha Stream has been altered as a result of development in the valley. A community member has shared that there used to be a natural detention basin mauka of the wetlands to the west of Kili Drive that was filled in with boulders during a construction project in the valley.

Properties located near the mouth of Mākaha Stream are exposed to higher flood risk due to the sand berm at the mouth of the stream that restricts the free flow of storm water to discharge into the ocean. Depending on wave action during the winter season, the beach berm can reach a height as high as the existing bridge along Farrington Highway. Storm water from Mākaha Stream is generally directed towards West Mākaha Stream as a result of the sand berm or may backwash into Mākaha Stream. When this condition occurs, the storm water contributes to flooding of adjacent properties and Farrington Highway due to the higher flood elevations.

Similarly, properties located near the mouth of Eku Stream are exposed to higher flood risk due to storm water that is constricted by Eku Stream Bridge. This bridge was built in 1989 and is inadequately sized to accommodate flows for a 100-year storm. Storm water that is constricted at the bridge may contribute to flooding of adjacent properties near the bridge.

Residents living in areas located near Eku Stream have described flooding of up to four feet on their properties during past rain events, from Eku Stream flooding and lack of drainage. Community members have shared that the majority of the flooding near Eku Stream is caused by large debris and blockage along the stream and at the bridge.

In addition to the absence of a comprehensive drainage system for the valley, some of the local drainage systems are damaged and have not been repaired. There is a breach in the berm located in the lower area of the valley near Mākaha Stream and also in the berm system located behind Mauna ‘Olu Estates.

Past history of this area reveals that an earthen berm was constructed to reroute Mākaha Stream in order to develop a residential subdivision (homes that are located on Manuku and Nukea Streets). The earthen berm in the lower valley was damaged during the 2008 storm when storm flows broke through the berm in an area where the stream makes an abrupt change in direction. As a result of the breach, properties located downstream from the berm experience flooding and erosion to their property during large storms. With the breach in the berm, Mākaha Stream now travels adjacent to the back yards of homes located on Manuku and Nukea Streets during large storms. Residents on these streets have reported flooding problems and property damage resulting from erosion and high velocity of runoff behind their properties since 2008.

Sections of the existing system of ditches and berms above the Mauna ‘Olu Estates subdivision are not functioning as originally constructed. One part of the earthen berm is level with the ditch. The BWS is currently studying alternative measures to improve this system. This may include improving only certain problematic areas or improving the entire system with possibly a new lined drainage ditch or levee walls. Also being addressed is the adequate dissipation of hydraulic energy at the outlet of any improvements. The implementing entity for these potential improvements has not been identified.

The majority of the roads in the lower residential area are private roads that do not contain drainage infrastructure. Runoff disperses as sheet flow, but during large storms these areas are subject to ponding. This condition has been identified for Noholio Road, Lahaina Street, and Mākaha Valley Road. Additionally, two swales (depressions) from the Mākaha West Golf Course run towards the ocean and travel through residential properties, contributing to flooding in this area.

Storm drains are often clogged with small debris and rocks during a storm, which contributes to storm water backup and has resulted in extensive flooding and major road damages. Kili Drive is a private road located on the northern side of Mākaha Valley starting at Farrington Highway and ending near the Mākaha Valley Towers, where it forms an intersection with the Mākaha Valley Towers entrance, Huipu Drive, and an access road to a BWS reservoir. Kili Drive has experienced severe road damages from rocks, debris, and clogged drains that gouge out sections of the pavement. This issue has resulted in extensive flooding of Kili Drive and has closed the road off to residents during storms.



Storm drains clogged with rocks

There is an existing ditch and berm system behind the Mākaha Valley Towers which collects runoff from the valley walls and directs it to a culvert that runs under Kili Drive, under and through the Mākaha Valley Plantation complex, and into Mākaha Stream. During the 2008 storm, runoff traveling down the reservoir access road was extensive enough to damage the pavement near the intersection before spilling onto Kili Drive, which contributed to turning parts of Kili Drive into a “river.” Kili Drive is often referred to as “Kili River” by community members.

5. Hydrologic Analysis

Hydrologic analysis estimates the volume of water entering and passing through a drainage system from a rainfall event. The purpose of the hydrologic analysis was to determine the peak flows of Mākaha and Eku Streams in order to identify flooding problems for the smaller, sub-basin areas of the valley. Flows from the hydrologic analysis were used in the hydraulic analysis in order to analyze possible flood mitigation measures. Peak flow discharges were calculated for the 10-, 25-, and 100-year flood events which correlate to the 10, 4, and 1 percent chance that a flood will occur in any given year.

While there are several methods to determine peak discharges, including using USGS regression equations, the Federal Emergency Management Agency's (FEMA) peak discharge-frequency drainage area curves, and Plate 6 from the City, the Technical Release 55 (TR-55) method published by the Natural Resources Conservation Service (NRCS) was used. The TR-55 method is recommended for estimating runoff and peak discharges for small watersheds. Win TR-55 (NRCS 2011), a computer software program that applies the TR-55 model, was used for this hydrologic analysis.

Mākaha and Eku Streams were delineated into subareas based on a tributary contributing runoff to the main stream. Note that Mākaha and West Mākaha Streams were modeled as a single stream in this analysis as was done by previous Flood Insurance Studies by FEMA. Centerline alignments—that defined the centerline of each stream—were created for both streams. Tributary points along the centerline alignment were then identified to delineate the tributary sub-areas and reaches. Tributary points for Mākaha Stream and Eku Stream are listed in Tables 1 and 2, respectively. A sub-area is defined as the land area that contributes runoff at a point along the flow path (stream); whereas a reach is defined as the major flow path (section of stream) through which runoff is routed. Six subareas were identified for Mākaha Stream and three for Eku Stream (**Figure 5**).

Table 1. Mākaha Stream Tributary Points

Point Number	Description	Stream Station
1	Beginning of study area	140+00
2	Existing limit of study	90+00
3	Intermediate point	70+00
4	Intermediate point	56+00
5	Intermediate point	30+00
6	End of study area	10+00

Table 2. Eku Stream Tributary Points

Point Number	Description	Stream Station
1	Beginning of study area	92+00
2	Existing limit of study	43+00
3	End of study area	5+00

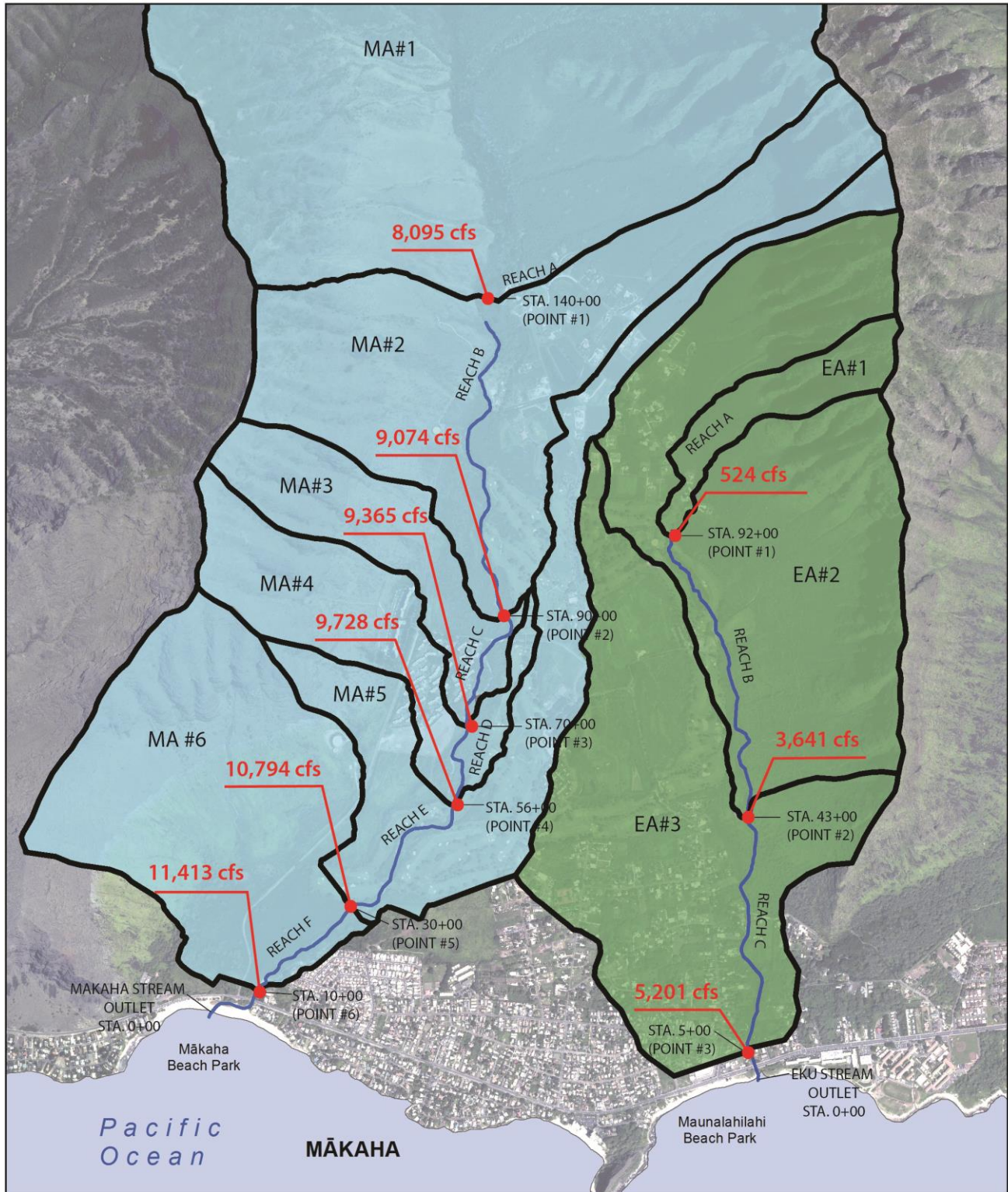

Mākaha Valley Flood Study

Figure 5. Tributary Area Map

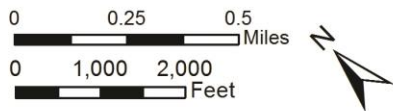

The WinTR-55 model includes inputting basin characteristics such as topography, soil type, land use, storm rainfall, and tributary area information. The other methods to determine peak discharges were felt to be too general because they only accounted for rainfall and area, whereas WinTR-55 accounted for differing land uses which is a significant factor for Mākaha. The results of the WinTR-55 peak flow calculations for the full build-out scenario for Mākaha Stream and Eku Stream are shown in Tables 3 and 4 respectively. The full build-out scenario assumes the development of the dozen or more large undeveloped parcels in Mākaha.

Table 3. Full build-out Peak Flows for Mākaha Stream

Sub-area or Reach	MĀKAHA STREAM: Peak flow (cfs) @peak time (hr)		
	10-year	25-year	100-year
Subarea 1 (MA#1)	4,285 cfs @ 10.59 hrs	5,783 cfs @ 10.58 hrs	8,095 cfs @ 10.55 hrs
Subarea 2 (MA#2)	1,458 cfs @ 10.11 hrs	1,966 cfs @ 10.12 hrs	2,737 cfs @ 10.13 hrs
Subarea 3 (MA#3)	601 cfs @ 10.06 hrs	799 cfs @ 10.07 hrs	1,100 cfs @ 10.06 hrs
Subarea 4 (MA#4)	626 cfs @ 10.09 hrs	826 cfs @ 10.09 hrs	1,124 cfs @ 10.10 hrs
Subarea 5 (MA#5)	598 cfs @ 10.40 hrs	809 cfs @ 10.38 hrs	1,138 cfs @ 10.40 hrs
Subarea 6 (MA#6)	1,585 cfs @ 10.02 hrs	2,120 cfs @ 10.02 hrs	2,931 cfs @ 10.01 hrs
Reach A @ Point #1			
Reach A @ Point #1	4,285 cfs @ 10.59 hrs	5,783 cfs @ 10.58 hrs	8,095 cfs @ 10.55 hrs
Reach B @ Point #2	4,809 cfs @ 10.54 hrs	6,496 cfs @ 10.52 hrs	9,074 cfs @ 10.55 hrs
Reach C @ Point #3	4,970 cfs @ 10.56 hrs	6,706 cfs @ 10.55 hrs	9,365 cfs @ 10.53 hrs
Reach D @ Point #4	5,163 cfs @ 10.54 hrs	6,964 cfs @ 10.55 hrs	9,728 cfs @ 10.53 hrs
Reach E @ Point #5	5,720 cfs @ 10.56 hrs	7,722 cfs @ 10.58 hrs	10,794 cfs @ 10.55 hrs
Reach F* @ Point #6	6,045 cfs @ 10.57 hrs	8,166 cfs @ 10.53 hrs	11,413 cfs @ 10.53 hrs

*Reach F is at end of the study. The study ended just above Farrington Highway due to limited available data.

To understand the peak flow calculations computed using WinTR-55 as shown above, for example for a 100-year storm for Mākaha Stream under the full build-out scenario, subarea 1 (identified on map as MA #1) generates 8,095 cfs at its peak flow and reaches its peak at about 10.55 hours from the start of the storm. Subarea 2 (identified on map as MA #2) generates 2,737 cfs at its peak flow at about 10.13 hours; 1,100 cfs, 1,124 cfs, 1,138 cfs, and 2,931 cfs for subareas 3 to 6 respectively.

Reach A is the section of the stream that flows through subarea 1 (MA#1). The amount of runoff that travels through the stream for this subarea is computed at Point #1 (Stream Station 140+00), which is equivalent to the amount of runoff generated by subarea A. Reach B is the section of the stream that flows through subarea 2 (MA#2) between Point #1 and Point #2. Similarly, the amount of runoff that travels through this section of the stream is computed at Point #2 (Station 90+00). The peak flow for Reach B at Point #2 is 9,074 cfs. Point #6 (10+00) is located at the end of the study area, located just above Farrington Highway, and measures the amount of runoff that travels through Reach F. The peak flow assuming full build-out of Mākaha Valley for a 100-year storm for Reach F at Point #6 is 11,413 cfs where peak flow is reached at about 10.53 hours from the start of the storm. Peak flows at Points #2 to #6 are cumulative.

Table 4. Full build-out Peak Flows for Eku Stream

Sub-area or Reach	EKU STREAM: Peak flow (cfs) @peak time (hr)		
	10-year	25-year	100-year
Subarea 1 (EA#1)	277 cfs @ 9.97 hrs	375 cfs @ 9.97 hrs	524 cfs @ 9.96 hrs
Subarea 2 (EA#2)	1,716 cfs @ 10.13 hrs	2,300 cfs @ 10.13 hrs	3,181 cfs @ 10.13 hrs
Subarea 3 (EA#3)	1,146 cfs @ 10.40 hrs	1,497 cfs @ 10.36 hrs	2,029 cfs @ 10.40 hrs
Reach A @ Point #1			
Reach A @ Point #1	277 cfs @ 9.97 hrs	375 cfs @ 9.97 hrs	524 cfs @ 9.96 hrs
Reach B @ Point #2			
Reach B @ Point #2	1,967 cfs @ 10.12 hrs	2,631 cfs @ 10.11 hrs	3,641 cfs @ 10.11 hrs
Reach C* @ Point #3			
Reach C* @ Point #3	2,853 cfs @ 10.18 hrs	3,792 cfs @ 10.18 hrs	5,201 cfs @ 10.18 hrs

*Reach C is at end of the study. The study ended just above Farrington Highway due to limited available data.

The calculated peak flows for a 10-, 25-, and 100-year storm for Mākaha Stream were 6,045 cfs, 8,166 cfs, and 11,413 cfs respectively. The calculated peak flows for a 10-, 25-, and 100-year storm for Eku Stream were 2,853 cfs, 3,792 cfs, and 5,201 cfs respectively. Note that the hydrologic analysis was completed just above Farrington Highway for both Mākaha and Eku Streams. Therefore, peak flows at the stream outlets into the ocean may be slightly higher. Complete peak flow calculations and hydrographs are provided in Volume III of this report.

Comparisons of full build-out versus existing conditions did not show a significant change in overall peak flows for Mākaha Stream. Peak flow for a 100-year storm at the end of the study area for Mākaha Stream for full build-out was 11,413 cfs compared to 11,326 cfs under existing conditions. Additionally, examination of the Mākaha Stream hydrograph generated by WinTR-55 shows subarea 1 (MA #1) as the major factor controlling the total peak flow at the downstream end of the stream. As shown in Table 3, subarea 1 generates 8,095 cfs at its peak flow. In other words, the majority of the runoff is contributed by subarea 1, which consists of forested lands owned by the BWS. Therefore, an increase in development within the lower reaches of Mākaha Stream will increase localized runoff rates and total runoff volumes, but total peak runoff rates for the stream will increase only by a relatively slight amount.

6. Hydraulic Analysis

The purpose of the hydraulic analysis is to identify flood areas based on the peak flow rates determined in the hydrologic analysis. Hydraulic analysis estimates the flow depths and points of overflow for a drainage system resulting from a known amount of water flow. Peak flow values determined from the hydrologic analysis were used in the Hydrologic Engineering Center River Analysis System (HEC-RAS), a computer program developed by the U.S. Army Corps of Engineers (USACE), to analyze the extent of inundated areas for Mākaha and Eku Streams including flood elevations for the 10-, 25-, and 100-year storms. Results from the HEC-RAS program are in Volume III of this report.

For Mākaha Stream, cross sections were generated along the stream alignment every 200 feet. For Eku Stream, cross sections were generated every 250 feet with the exception of the downstream flat areas where the cross sections were increased to every 50 feet to better analyze water flow paths. Note that the generated cross sections are only as accurate as the available topographic data. Full build-out peak flows from WinTR-55 were inputted into the HEC-RAS. Inundation areas and water levels were determined for both streams for the 10-, 25-, and 100-year storms.

Analysis showed that Eku Stream is well defined and contained until approximately 3,800 feet upstream of the mouth. Below this point, the existing Eku Stream channel cannot contain the design storm, and as a result, runoff flows outside of the channel creating a path of shallow flooding which approaches 2,500 feet in width just upstream of Farrington Highway. For Eku Stream, the 10-, 25-, and 100-year flood limits in the upper elevations differ only slightly because of the deeper and more defined stream cross



Flat terrain in the lower areas of Eku Stream near Farrington Highway (facing makai)

sections. As Eku Stream reaches the lower elevations, the limits differ somewhat due to the very flat terrain found in some areas. A ground elevation difference of six inches can result in a horizontal difference of 50 to 100 feet between flood limits of different recurrences. See Figures 6 and 7 for the 10-, 25-, and 100-year flood limits for Mākaha Stream and Figure 8 for Eku Stream. The figures also show the calculated flood surface elevations at selected locations. For Mākaha Stream, the banks are more defined and therefore the flood limits differ only slightly for the 10-, 25-, and 100-year storms. The flood elevations range from two to seven feet within the streambed of Eku Stream, while flood elevations within the floodplain for Eku Stream can range from zero to three feet. Flood depths for Mākaha Stream range from five to over ten feet within the streambed and can range from zero to four feet in the Mākaha Stream floodplain.

The difference between the flood zones of this study and the published FEMA flood zones is mainly due to the difference in the terrain mapping. This study utilized a combination of land survey data and Light Detection and Ranging (LIDAR⁷) data taken in 2008 or later, which was not used to model the current FEMA maps. In areas where the topography is flat, the inundation limits can differ significantly even with small differences between BFEs of both studies. For example, in the lower lying areas of Eku Stream, the differences between the 100-year flood zone of this study and that of FEMA's is significantly different. The same stream in the higher elevations is almost identical because of the well-defined and steeper slopes of the stream banks.



Project team standing to the left of the Mākaha Stream berm

It is also important to note that the flow for Eku Stream in this study (4,650 cfs) is approximately 450 cfs higher than the flow published by FEMA (4,200 cfs). It is speculated that the difference is due to the different methods used to calculate the flow. This study used WinTR-55 and it is likely that the FEMA study did not. WinTR-55 allows inputting factors that simulate the surface water retention characteristics, which is important when it is necessary to compare the differences in flows between current build-out and full build-out of the urban tributaries, as described in Section 5 “Hydrologic Analysis.” The linear regression method, for example, does not. The Mākaha Stream flows calculated in this study and FEMA's are almost identical.

Hydraulic analysis for this study did not account for anticipated sea level rise because the study area ended approximately 150 feet upstream of Farrington Highway. Further analysis will be required to incorporate impacts anticipated from sea level rise for proposed structural projects.

⁷ A remote sensing technology that uses light in the form of a pulsed laser to measure distances to the Earth.



Mākaha Valley Flood Study

Figure 7. Mākaha Stream Flood Map

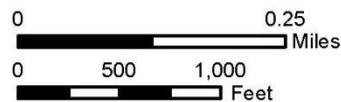

For: State DLNR
October 2014

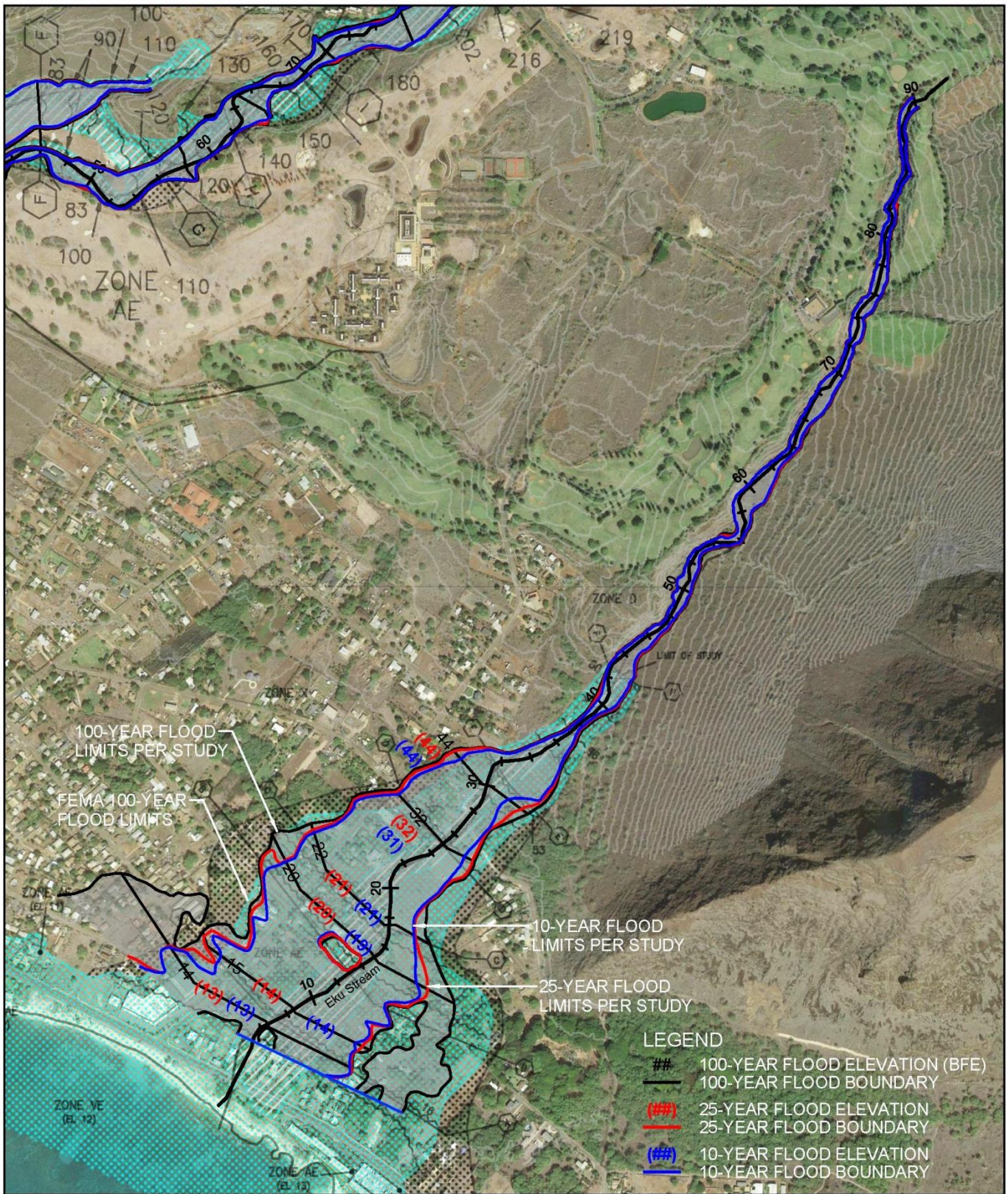

Mākaha Valley Flood Study

Figure 8. Eku Stream Flood Map

0 0.25 Miles

0 500 1,000 Feet



For: State DLNR
October 2014

7. Proposed Flood Mitigation Measures

The purpose of this section is to describe flood mitigation projects for Mākaha Valley. These projects were developed based on hydrologic and hydraulic analysis of the area and discussions with community members. A general effectiveness analysis of each proposed flood mitigation project is included by examining estimated project cost, storm damages without the project, and benefits from implementation of the project. Estimated project cost includes costs associated with land acquisition and obtaining easements that may be required depending on the project location; environmental fees to complete an Environmental Assessment (EA) and any State and City approvals and permits; survey and design (includes topographic mapping, geotechnical work, and engineering); construction management; and construction of the project. A ten percent contingency is included in the construction cost estimate. Benefits may include, but are not limited to, avoided requirement to purchase flood insurance, avoided environmental impacts, avoided damage costs from flooding, and increased property values.

The recommended flood mitigation measures are grouped into two types of actions: structural projects and nonstructural programs. The structural projects require some type of construction while the nonstructural programs relate to an ongoing set of activities. Table 5 lists the proposed structural projects and nonstructural programs. **Projects are not numbered in order of importance.**

Table 5. Proposed Flood Mitigation Measures

Structural Projects	Nonstructural Programs
<ol style="list-style-type: none"> 1. Eku Stream Channel and Off-line Detention Basin 2. New Eku Stream Bridge at Farrington Highway 3. Noholio Road Drain Line 4. Repair the breach in the Mākaha Stream berm 5. Mākaha Stream Levee 6. Kili Drive Channel 7. Mauna ‘Olu Estates Drainage Improvements 8. In-stream Detention Basins for Mākaha Stream 9. Restore Mākaha Surfing Beach “Pond” 	<ol style="list-style-type: none"> 1. Forest Restoration 2. Stream Channel Maintenance 3. Storm Drain Maintenance 4. Enforcement of existing legislation 5. Education on Best Management Practices for Watersheds 6. Drainage improvements required for future development

7.1 Structural Projects

Generally, the projects included in this section are “stand-alone” projects, which mean that the recommended project can be constructed independently of the other projects. Project designs may change slightly based on the implementation of another project.

Proposed improvements to Eku Stream include: widening the existing channel; lining the channel with concrete, gabion baskets, grouted rip-rap, or other methods; construction of an off-line detention basin; and widening of the Eku Stream bridge along Farrington Highway.

Proposed improvements to Mākaha Stream include: repairing the berm, protecting the area with a levee, and in-stream detention basins. The Kili Drive Channel would catch runoff from the northwestern side of the valley and convey it into West Mākaha Stream, thereby reducing some of the runoff that would otherwise be discharged into Mākaha Stream. Table 6 provides a summary of total estimated cost for the structural projects, assuming fully engineered “robust” construction materials.

Table 6. Summary of Estimated Cost for Structural Projects

Project No.	Mitigation Measure	Total Estimated Cost
1	Eku Stream Channel and Off-line Detention Basin	\$27,767,000 - \$34,767,000
2	New Eku Stream Bridge at Farrington Highway	\$12,000,000 - \$19,000,000
3	Noholio Road Drain Line	\$1,700,000 - \$3,300,000
4	Repair the breach in the Mākaha Stream berm	\$300,000 - \$450,000
5	Mākaha Stream Levee	\$17,021,000 - \$24,021,000
6	Kili Drive Channel	\$12,000,000 - \$19,000,000
7	Mauna ‘Olu Estates Drainage Improvements	To be determined
8	In-stream Detention Basins for Mākaha Stream	\$13,000,000 - \$18,000,000
9	Restore Mākaha Surfing Beach “Pond”	To be determined
TOTAL ESTIMATED COST		\$83.5 - \$118.1 million¹

¹The total estimated cost does not include Project No. 4 “Repair the breach in the Mākaha Stream berm” as it would not be necessary with the construction of Project No. 5: “Mākaha Stream Levee.”

Recognizing that these high costs will be difficult to fund, the project team also developed a set of alternative costs that assume the use of earthen berms and channels. While the estimated cost of alternative methods is significantly lower, these alternative mitigation measures will require higher levels of maintenance; therefore ongoing maintenance costs will be greater for the alternative methods.

Table 7. Summary of Alternative Costs for Structural Projects

Project No.	Mitigation Measure (Alternative Method)	Total Estimated Cost
1	Eku Stream Channel with erosion control matting	\$10,000,000 - \$11,000,000
5	Repair existing Mākaha Stream berm	\$500,000 - \$600,000
6	Kili Drive Channel with erosion control matting	\$1,300,000 - \$1,500,000
TOTAL ESTIMATED COST WITH ALTERNATIVE METHODS		\$38.8 - \$ 53.9 million¹

¹The total estimated cost replaces the estimated cost for Projects No. 1, 5, and 6 with estimated cost for the alternative method; and includes the cost for Project No. 4 "Repair the breach in the Mākaha Stream berm."

7.1.1 Project No. 01: Eku Stream Flood Channel and Off-Line Detention Basin

Improvements to Eku Stream are recommended to extend upstream 3,800 feet to where the existing channel's capacity is exceeded. Calculations show that with the quantity of runoff, along with natural grades of the area, the velocity of the runoff will be too high for the channel to be unlined. The channel may be lined with concrete, gabion baskets, grouted rip-rap, or other methods. The channel will be 3,800 feet in length.



Eku Stream Channel near Farrington Highway facing makai

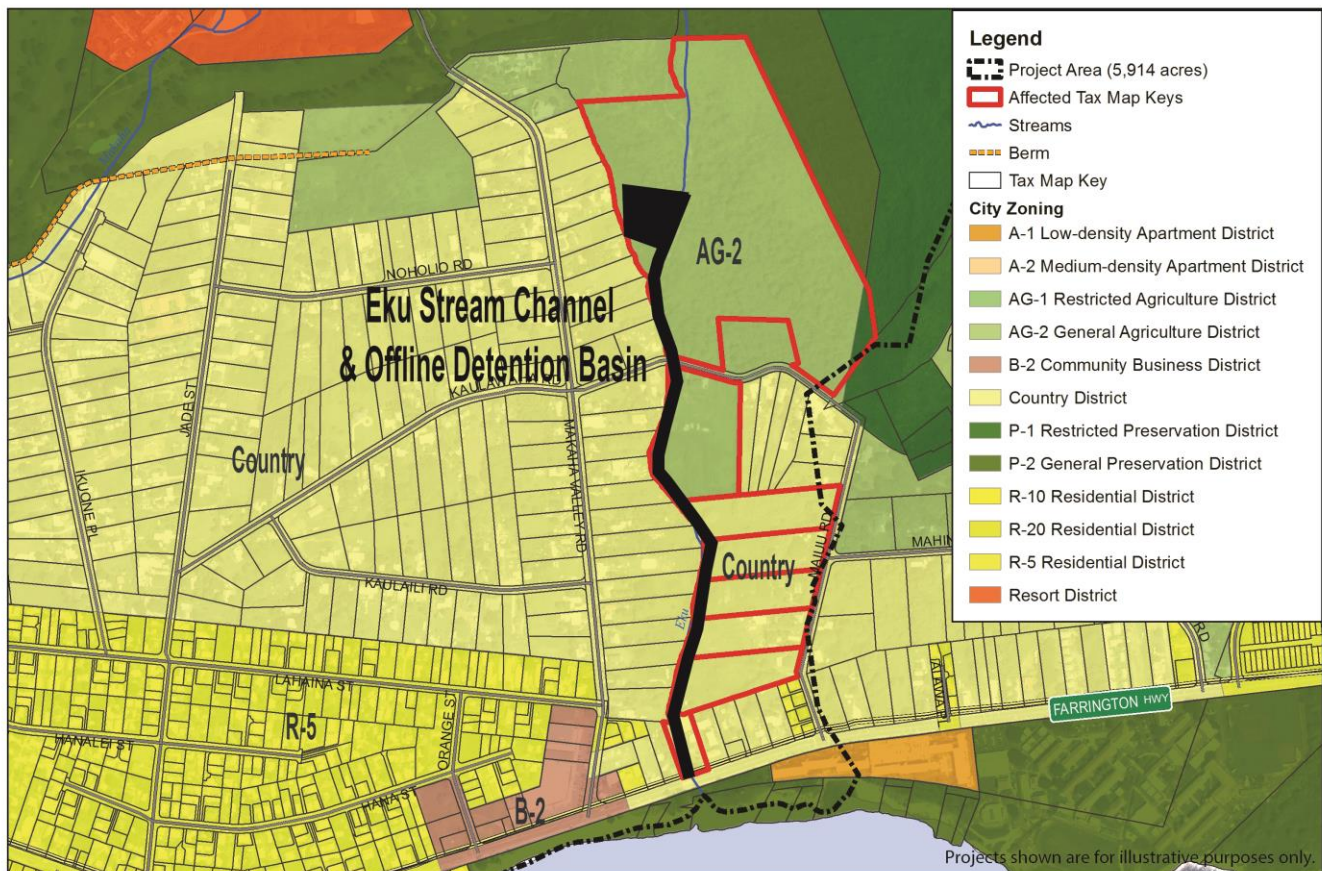
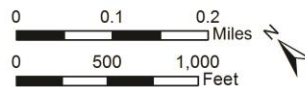

Figure 10. Eku Stream Flood Channel and Off-line Detention Basin Project Location



For a trapezoidal shaped concrete-lined channel, an 84-foot Right of Way (ROW) will be needed. The ROW includes a 16-foot wide maintenance road. The concrete channel will need to be approximately 40 feet wide at the base, 68 feet wide at the top of the channel, and 5 feet deep with side slopes of 2 to 1.

For a trapezoidal shaped gabion or grouted rip-rap channel, a 100-foot wide project easement will be needed. The ROW includes a 16-foot wide maintenance road. The gabion or grouted rip-rap channel will need to be approximately 50 feet wide at the base, 84 feet wide at the top of the channel, and 6.5 feet deep with side slopes of 2 to 1.

If the channel itself is used as a maintenance road, then the 16-foot wide maintenance road can be eliminated. Therefore, the ROW may only need to be 68 feet for the concrete channel and 84 feet for the gabion or grouted rip-rap channel.

A 5.5-acre off-line detention basin will need to be constructed at the mauka end of the flood channel. The basin will have an average depth of 8.5 feet, which would contain approximately 1,555,000 cubic feet of runoff. The purpose of this basin is to limit the flow traveling along Eku Stream downstream of this point. Therefore, the design will include an overflow weir along the channel that will overtop once the flow in the channel reaches a certain rate (preliminary estimate is 2,000 cfs), and will direct the excess flow to the detention basin.

The Eku Stream Channel and Off-line Detention Basin are designed to “contain” the 100-year storm. Useful life of the project is about 50 years.

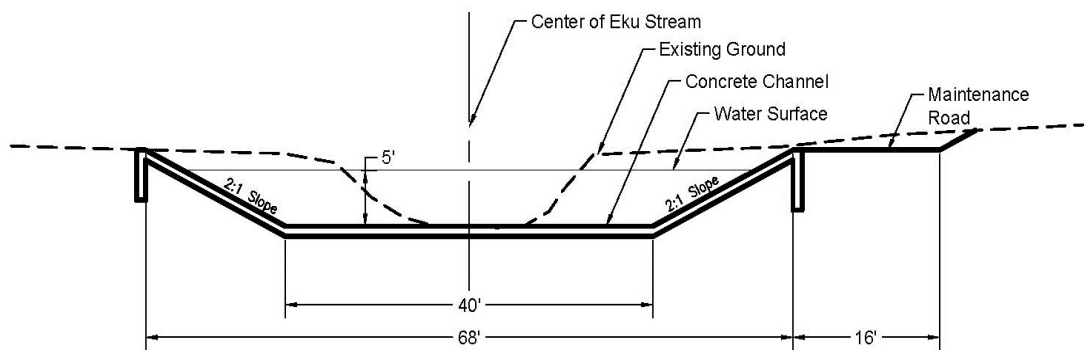

Eku Stream - Concrete Channel

Looking Makai

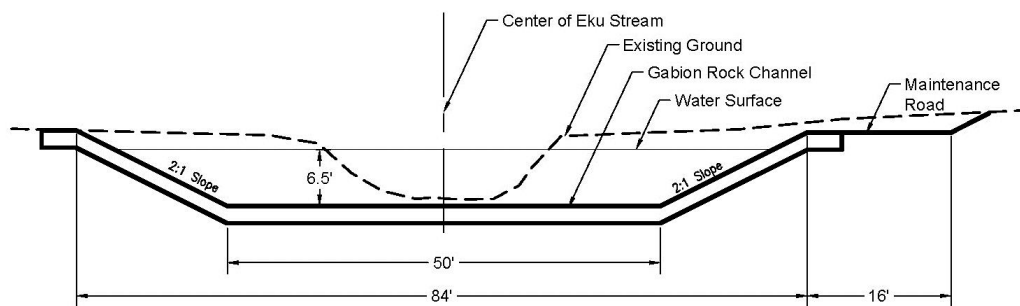

Eku Stream - Gabion Rock Channel

Looking Makai

Implementing Agency

To be determined

Ongoing Maintenance Agency

To be determined

Estimated Project Cost

The estimated cost to construct the Eku Stream Flood Channel and Off-line Detention Basin ranges from \$27,767,000 to \$34,767,000. This estimated cost includes acquiring one property on Farrington Highway adjacent to the stream and obtaining easements for eight parcels owned by different landowners. Six of the eight parcels for which easements need to be obtained are zoned for country use while the other two parcels are zoned for agricultural use. The recommended channel would also intersect Kaulawaha Road, which according to the City's property information data is owned by Mākaha Valley Farms Ltd.

Based on the City's assessed values as of October 1, 2009, the property on Farrington Highway has an assessed building and land value of \$310,000 while the eight easements have an estimated value totaling \$457,000⁸. Only one property will need to be acquired because the proposed channel would be constructed on lots that have been zoned for country use, meaning that the lots are at least one acre in area and 100 feet wide. All of the existing homes on the parcels for which easements need to be obtained are located near the road and away from the stream where the channel would be built. As a result, the areas within the parcel that would be impacted due to the proposed flood channel are generally the backyards of homes, with the exception of one property near Farrington Highway where a significant section of land would be required due to the orientation of the parcel.

Cost Item	Estimated Cost
Acquisition	\$310,000 ^a
Easements	\$457,000 ^{a,b}
Environmental	\$500,000 - \$1,000,000
Survey and Design	\$1,000,000 - \$2,000,000
Construction Management	\$500,000 - \$1,000,000
Construction	\$25,000,000 - \$30,000,000
Total	\$27,767,000 - \$34,767,000

^a Based on City's Assessed Values as of October 1, 2009.

^b Easement values were estimated based on using a percentage of the assessed land value equivalent to the percentage of the total area required for the flood mitigation project for each parcel. Values are based on a 100-foot wide easement.

⁸ Easement values were estimated based on using a percentage of the assessed land value equivalent to the percentage of the total area required for the flood mitigation project for each parcel. Values are based on a 100-foot wide easement.

An alternative flood mitigation project to lining the Eku Stream channel with concrete or gabion baskets is lining it with erosion control matting. Simply grading channels and leaving them unprotected from erosion would not be in conformance with the DOH requirements. The City requires that flow velocities in earthen channels, including those lined with erosion control matting, do not exceed five feet per second. The Eku Stream channel would exceed this velocity if the gabion lined channel dimensions for Eku Stream were kept the same but lined with ECM instead. The City would not approve the channel if they were to own and maintain it. However, if the Eku Stream channel is privately-owned, the City would not have jurisdiction with regards to design standards. The State DLNR does not have standards for channel velocities. However, the State DLNR recommends following the City's standards.

In-stream detention basins can be used in lieu of or in combination with off-line detention basins at different locations depending on the terrain and availability of land.

Storm Damages w/o the Project

At least 80 parcels including residential and commercial properties will continue to be affected by the 100-year storm.

Benefits w/ the Project

The benefits of constructing the Eku Stream Flood Channel and Off-line Detention Basin are:

- Protecting both residential and commercial properties from property damages resulting from storms up to the 100-year storm
- Reducing or eliminating flood insurance costs
- Removing 57 residential units and business parcels from the 100-year flood zone with total assessed building value of \$14,467,200
- Removing approximately 16 undeveloped parcels from the 100-year flood zone
- Increased property values from reduced flood risk

Flood insurance requirements for these structures in the high risk area would no longer apply with the construction of this project since these structures would be removed from the 100-year flood zone. Therefore, there would be significant savings from flood insurance avoidance in addition to flood damage avoidance. Federal subsidies for flood insurance are expected to be reduced and possibly eliminated with the implementation of recently passed laws. Homeowners would then be responsible for paying for the full-risk rates. As of July 2013, more than 76 percent of flood insurance policies on the Wai'anae Coast were subsidized.

7.1.2 Project No. 02: New Eku Stream Bridge at Farrington Highway

Construct a new reinforced concrete bridge at Farrington Highway crossing Eku Stream. As-built plans of the existing bridge show that the 100-year peak flow used in the design of the bridge was 2,500 cfs. However, the calculated 100-year peak flow as part of this study that was noted in the previous section for a point just upstream of Farrington Highway is 5,201 cfs. Even with the use of the recommended off-line detention basin, the calculated 100-year peak flow as part of this project was found to be 3,900 cfs, which is 1,400 cfs more than the capacity of the existing bridge for Eku Stream at Farrington Highway. The useful life of a new bridge would be 50 years.



Eku Stream Bridge along Farrington Highway

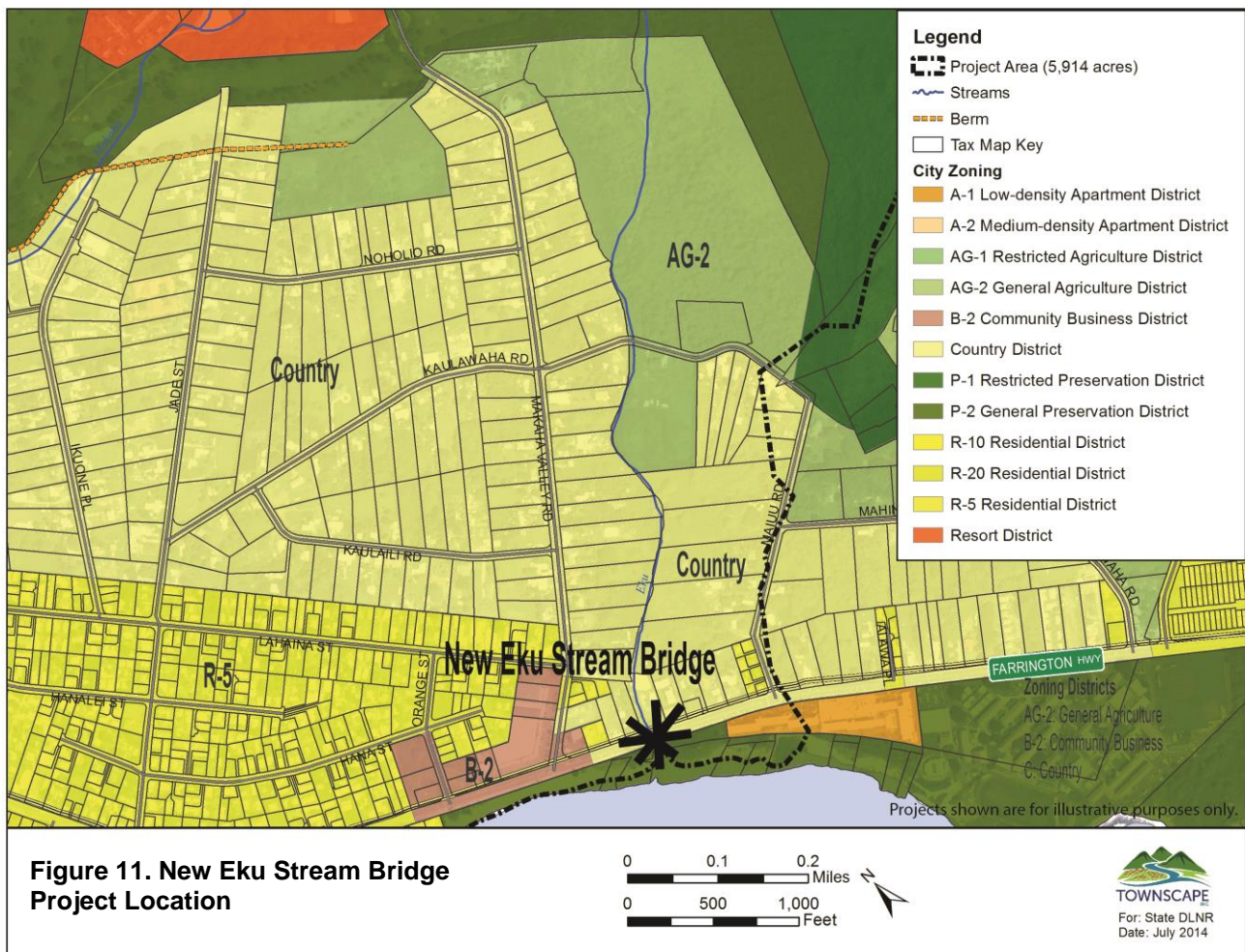

While the State Department of Transportation (DOT) is mandated by the Federal Highway Administration to replace or retrofit bridges that are rated structurally deficient by inspection, the DOT has no mandate to replace bridges due to hydraulic deficiencies.

Implementing Agency

State Dept. of Transportation, Highways Division

Ongoing Maintenance Agency

State Dept. of Transportation, Highways Division

Estimated Project Cost

The estimated cost to construct the new Eku Stream Bridge ranges from \$12,000,000 to \$19,000,000.

Cost Item	Estimated Cost
Acquisition	To be determined
Easements	To be determined
Environmental	\$500,000 - \$1,000,000
Survey and Design	\$1,000,000 - \$2,000,000
Construction Management	\$500,000 - \$1,000,000
Construction	\$10,000,000 - \$15,000,000
Total	\$12,000,000 - \$19,000,000

Storm Damages w/o the Project

Properties upstream from the bridge and Farrington Highway will continue to be affected by flooding from storm water that is constricted at the existing Eku Stream Bridge since it does not have adequate capacity to handle a 100-year storm. Flooding on Farrington Highway near Eku Stream poses a great danger to vehicles and restricts access for residents and emergency vehicles into Mākaha Valley and beyond.

Benefits w/ the Project

The benefits of constructing a new Eku Stream Bridge are:

- Reduced flooding of properties upstream from the bridge and Farrington Highway because storm water can freely flow under the bridge and discharge into the ocean
- Minimized risk of flooding on Farrington Highway that poses a threat to public safety due to lack of accessibility into Mākaha Valley and beyond

7.1.3 Project No. 03: Noholio Road Drain Line

Noholio Road is a private road within Mākaaha Valley that connects Jade Street to Mākaaha Valley Road. There are two depressions which collect runoff from the dwellings on the mauka side of the road as well as from some areas of the Mākaaha East Golf Course. The property owners on the makai side of Noholio Road at these two depressions have both constructed solid walls along the frontage of their properties, which effectively act as dams trapping the water and causing localized flooding. There does not appear to be any drainage easements in the vicinity of these two depressions, therefore, the recommendation for this area is a closed culvert system.

Grated drain inlets will be installed along the makai shoulder at the low points of both depressions. A 36-inch culvert will connect these two inlets and travel along Noholio Road to Mākaaha Valley Road, then to Kaulawaha Road, and finally empty into Eku Stream. The total length of this drain line will be approximately 2,500 feet. Because of the terrain in this area, the slope of the culvert will be minimal. Therefore, manholes should be placed at regular intervals for ease of maintenance. The grated inlet boxes will need to be maintained and cleaned before and after each storm event.

Improvements to Eku Stream are recommended prior to installing the Noholio Road drain line.

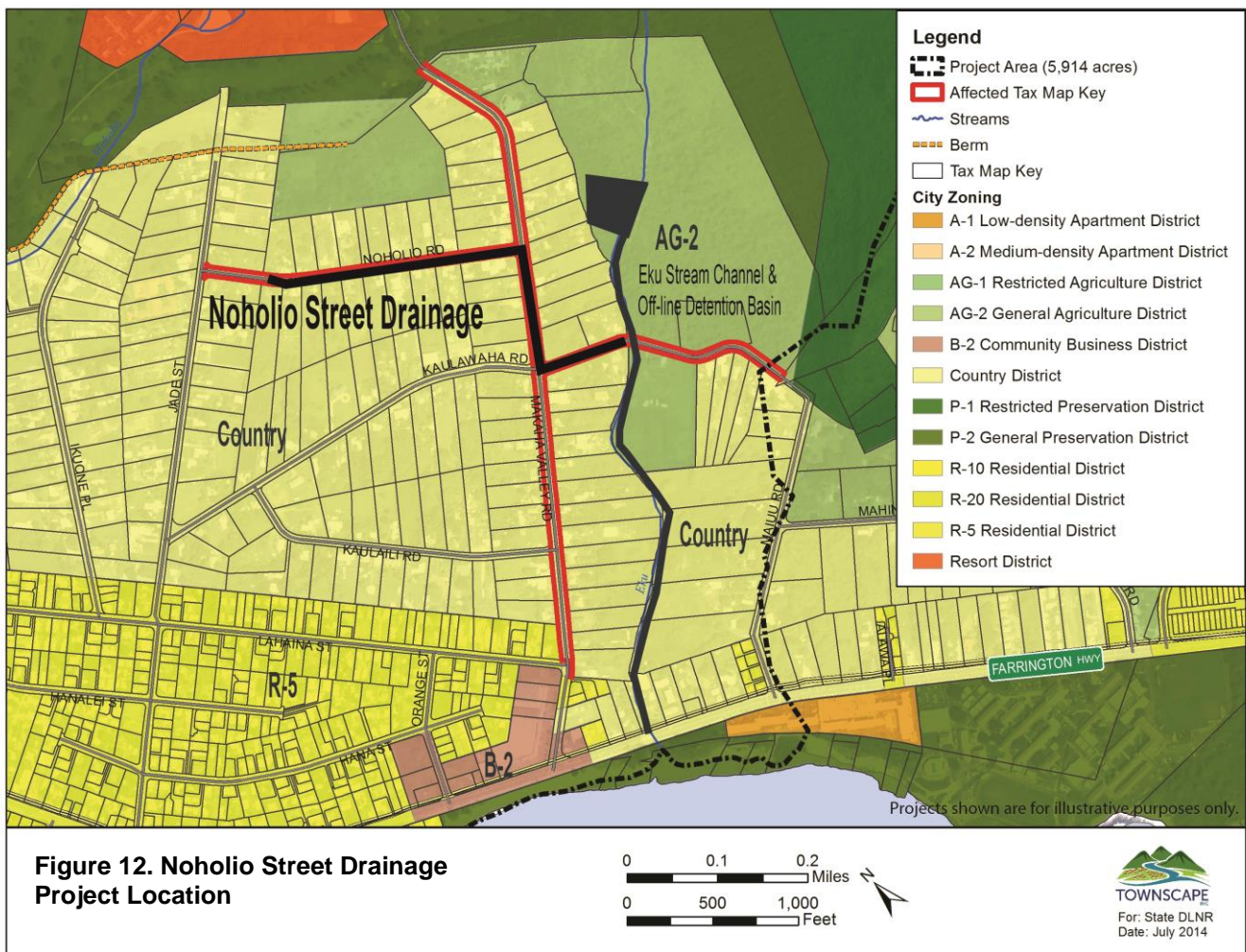

Implementing Entity

To be determined

Ongoing Maintenance Entity

To be determined

Estimated Project Cost

The estimated cost to construct the Noholio Road drain line is approximately \$1,700,000 to \$3,300,000. Noholio Road (TMK 8-4-022:034) is a privately owned road. The listed owner (as of July 2014) based on the City's data is Mākaha Valley Farms Ltd.

Cost Item	Estimated Cost
Acquisition	None
Easements	To be determined
Environmental	\$200,000 - \$400,000
Survey and Design	\$300,000 - \$500,000
Construction Management	\$200,000 - \$400,000
Construction	\$1,000,000 - \$2,000,000
Total	\$1,700,000 - \$3,300,000

Storm Damages w/o the Project

Homes on and makai of Noholio Road will continue to be affected by runoff locally and from mauka areas. Properties adjacent to the solid walls constructed by property owners will continue to be affected by localized flooding.

Benefits w/ the Project

The benefits of constructing the Noholio Road Drain Line are:

- Reduced flooding of Noholio Road and some areas of Mākaha Valley Road and Kaulawaha Road
- Reduced flooding of properties adjacent to solid walls constructed by properties owners

7.1.4 Project No. 04: Repair the Breach in the Mākaha Stream Berm

Repair the earthen berm at the breach, located on Tax Map Key (TMK) 8-4-002:063, with a hard surface such as concrete because the breach is located at a point where the stream makes an abrupt change in direction. This project will return Mākaha Stream to pre-2008 conditions, but should only be considered as a temporary solution. Visual inspection of this berm system revealed that the earthen berms are eroding, and while they may last many more years, other breaks may occur in the future.



Project team members walk sections of the earthen berm

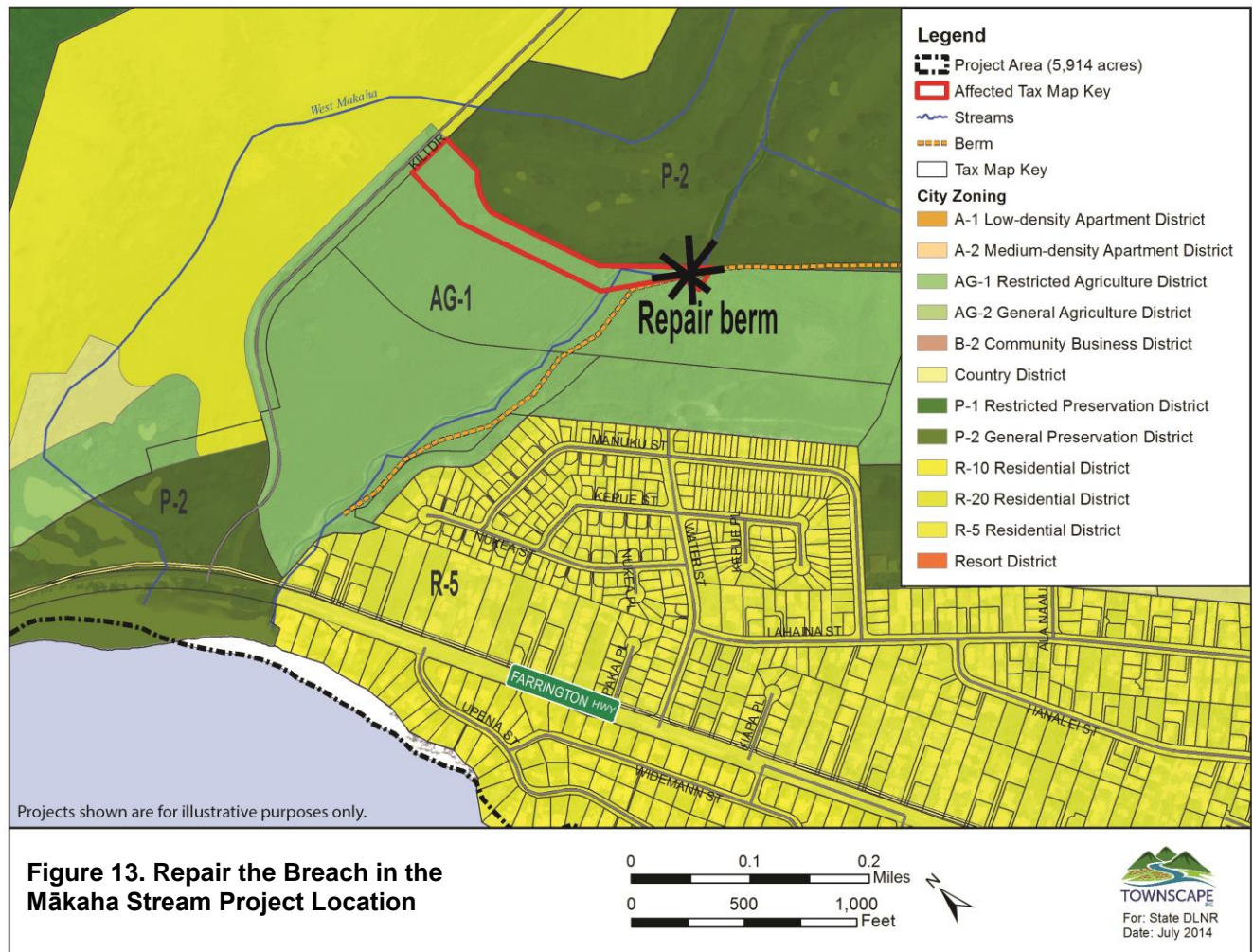

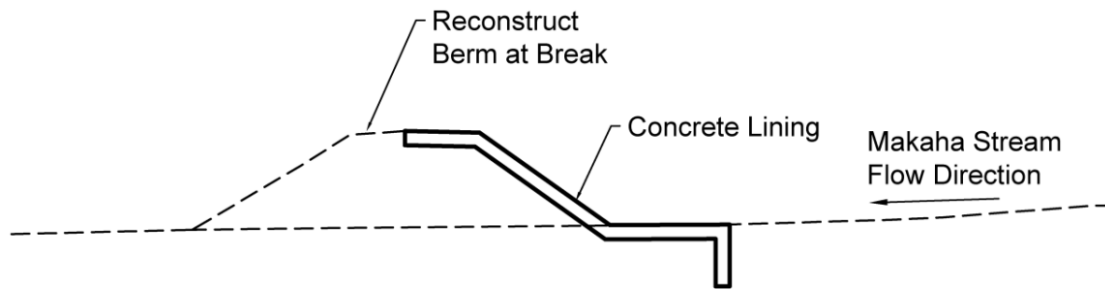

Repair Makaha Stream Berm

Looking Westerly

Implementing Agency

Mākaha Valley Road LLC⁹

Ongoing Maintenance Agency

Mākaha Valley Road LLC

Estimated Cost

The estimated cost to repair the breach in the berm is approximately \$300,000 to \$450,000. The recommended project is located on undeveloped land (TMK 8-4-002:063) owned by Mākaha Valley Road LLC. In accordance with Act 76 (2009), “the governor is authorized to designate state employees to enter on private property to mitigate hazardous situations after giving the landowner and occupier notice and a reasonable opportunity to mitigate the hazardous situation without assistance of the State.”

Construction drawings for this project are required to be submitted to the BWS Capital Projects Division for review and approval prior to any work on the berm along Mākaha Stream to ensure no negative impacts to the BWS water mains in the area.

Cost Item	Estimated Cost
Acquisition	None
Easements	None
Environmental	\$14,000
Survey and Design	\$36,000
Construction Management	\$40,000
Construction	\$210,000 - \$360,000
Total	\$300,000 - \$450,000

⁹ Listed land owner of TMK 8-4-002:063 on the City’s Property Information as of July 2014.

While a less costly alternative to this proposed project would be to only reconstruct the area of the earthen berm that is damaged, the high flow velocity due to the abrupt change in direction of the stream at that location will erode the berm again if it is not lined with a hard surface. Use of cement rubble masonry, gabion baskets, or reinforced concrete walls is needed.

Storm Damages w/o the Project

Properties downstream of the breach will continue to be flooded during large storms as storm water travels directly adjacent to some of the homes, and at times overflows into their backyards. Erosion of properties resulting from the velocity of storm water runoff will continue.

Additionally, from field observation, it appears that some residents have “extended” their “living space” into the area where storm water during a large storm would flow through the breach in the berm. For example, one household has a swing set in the area where flood waters will travel.

Benefits w/ the Project

The benefit of repairing the breach in the berm is to protect properties downstream of the breach that were previously protected from flooding before 2008. However, it is important to note that this mitigation measure should be considered a temporary solution as other breaks along the existing berm may occur in the future.

7.1.5 Project No. 05: Mākaha Stream Levee

Construct a reinforced concrete levee (flood wall) system along the northern and western side of affected properties located on Manuku and Nukea Streets. The levee will extend approximately 1,700 linear feet in length in an easterly/southeasterly direction near the rear boundary of these homes and the intent is to connect this proposed levee with the Department of Transportation’s bridge replacement project for Mākaha Stream. A 30-foot wide easement is recommended, which includes a 16-foot wide maintenance road to be constructed on the southeastern side parallel to the flood wall. An additional 350-linear foot easement is recommended from the approximate end of the levee behind homes located on Manuku Street to Water Street. The purpose of this additional ROW is to provide maintenance access via Water Street to the approximate end of the levee. The height of the concrete levee will vary depending on the existing topography, but the levee will extend at least three times its height above ground into the existing ground for maximum stability.

This project will remove homes from the 100-, and possibly the 500-, year floodplain. The useful life of this project is 50 years.

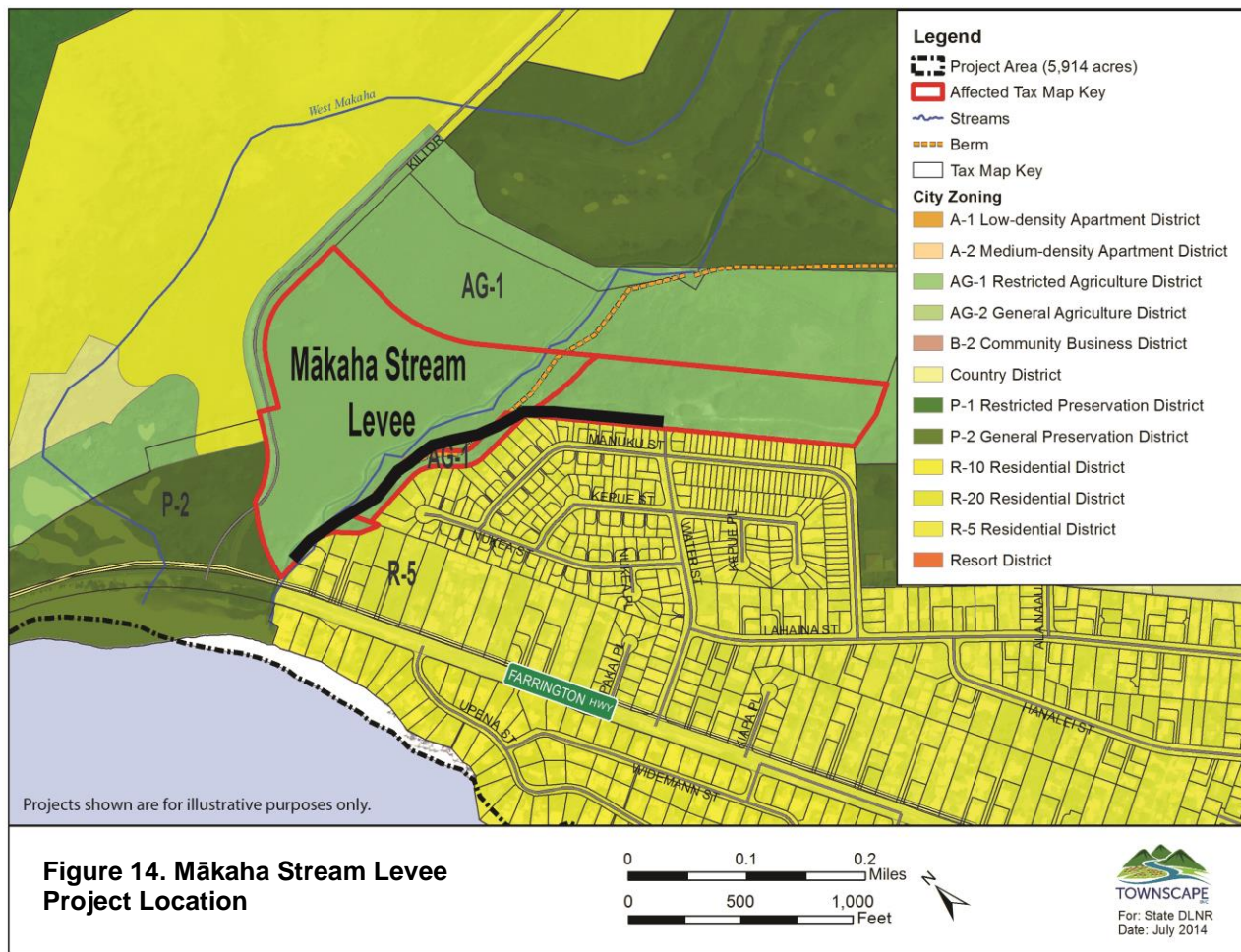

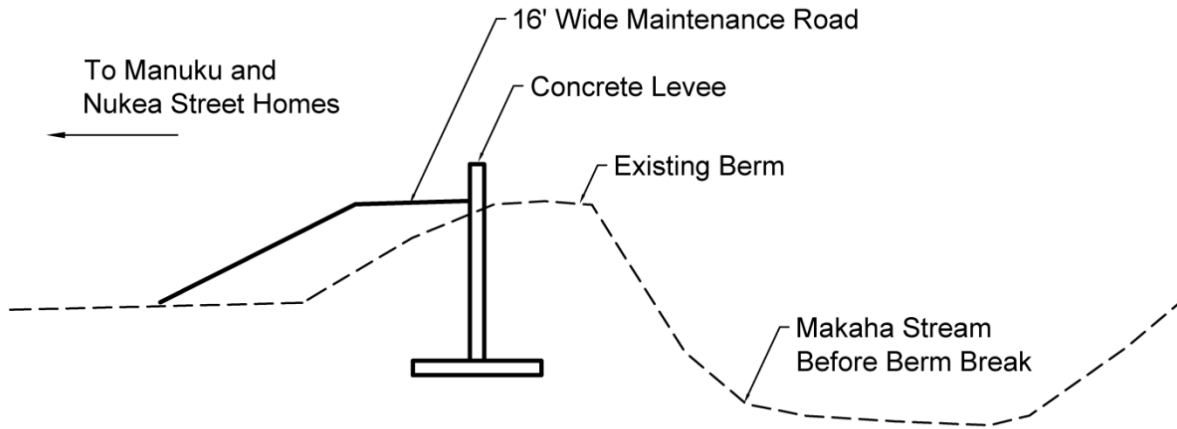

Makaha Stream Levee

Looking Makai

Implementing Agency

HRT, Inc.; Mākaha Valley Road LLC; Mākaha Valley, Inc.

Ongoing Maintenance Agency

To be determined

Estimated Project Cost

The estimated cost to construct the Mākaha Stream Levee is between \$17,021,000 and \$24,021,000. This estimated cost includes obtaining easements for three undeveloped parcels (estimated value totaling \$21,000¹⁰) from three different landowners. Based on the City’s property information (as of July 2014), the landowners are HRT, Inc., Mākaha Valley Road LLC, and Mākaha Valley, Inc.

Cost Item	Estimated Cost
Acquisition	None
Easements	\$21,000 ^a
Environmental	\$500,000 - \$1,000,000
Survey and Design	\$1,000,000 - \$2,000,000
Construction Management	\$500,000 - \$1,000,000
Construction	\$15,000,000 - \$20,000,000
Total	\$17,021,000 - \$24,021,000

^a Based on City’s Assessed Values as of October 1, 2009. Easement values were estimated based on using a percentage of the assessed land value equivalent to the percentage of the total area required for the flood mitigation project for each parcel. Values are based on a 30-foot wide easement.

¹⁰ Easement values were estimated based on using a percentage of the assessed land value equivalent to the percentage of the total area required for the flood mitigation project for each parcel. Values are based on a 30-foot wide easement.

A less costly alternative to constructing the concrete flood wall is to improve the existing earthen berm. The existing Mākaha Stream berm is approximately 12 to 15 feet wide at the top and eight feet high with varying slopes. The slopes vary due to scour and erosion over time. The berm is approximately 2,100 feet in length from the breach in the berm (located on TMK 8-4-002:063) to Farrington Highway. The project team walked sections of the berm, but it was difficult to see the berm in some areas as parts of the berm are no longer there. Sections of the berm will need to be completely reconstructed.



Signs of erosion and scour on the existing earthen berm

It is assumed that approximately half of the entire berm will need to be reconstructed. A detailed topographic survey of the existing berm will need to be conducted to get a better estimate. A new grading plan would need to be provided and approved by the City. The required State permits would need to be obtained along with a FEMA Letter of Map Revision since one was not obtained when the original berm was constructed.

Estimated cost for improving the existing earthen berm is approximately \$500,000 to \$600,000. This estimated cost includes engineering, permits, and construction management. Improving the existing Mākaha Stream berm will also require repairing the breach in the berm (Project No. 04 which was estimated to be between \$300,000 and \$450,000) in order to protect downstream properties from flooding.

Storm Damages w/o the Project

Homes and undeveloped parcels adjacent to Mākaha Stream near Manuku Street, Nukea Street, and Farrington Highway will continue to be flooded during large storms and edges of properties that are adjacent to the stream will be eroded from the velocity of storm water runoff. Homes and undeveloped parcels will remain within the 100- and 500-year floodplains.

Benefits w/ the Project

The benefits of constructing the Mākaha Stream Levee are:

- Protecting residential properties from property damages resulting from storms up to the 100-year storm
- Alleviating flooding of at least 12 existing homes and 5 undeveloped parcels from the 100-year storm
- Protecting at least 40 homes from the 500-year storm
- Reducing or eliminating flood insurance costs

7.1.6 Project No. 06: Kili Drive Channel

Construct a trapezoidal shaped, open concrete-lined ditch that is ten feet wide at the base, 24 feet wide at the top of the channel, five feet deep, and with side slopes of 1-vertical to 1-horizontal. The channel will begin at the mauka end of the Mākaha Valley Towers complex and travel along the BWS Reservoir access road and Kili Drive to where West Mākaha Stream crosses Kili Drive at the existing cluster of 30-inch culverts. It may be possible to end the ditch before the West Mākaha Stream crossing, but that is dependent on more detailed survey and study of the area.



Road damage on the BWS Reservoir Road due to flooding

This channel needs to be lined due to the high velocity of the runoff. In order to have the entire ditch as an open channel, it will require the removal of Monkey

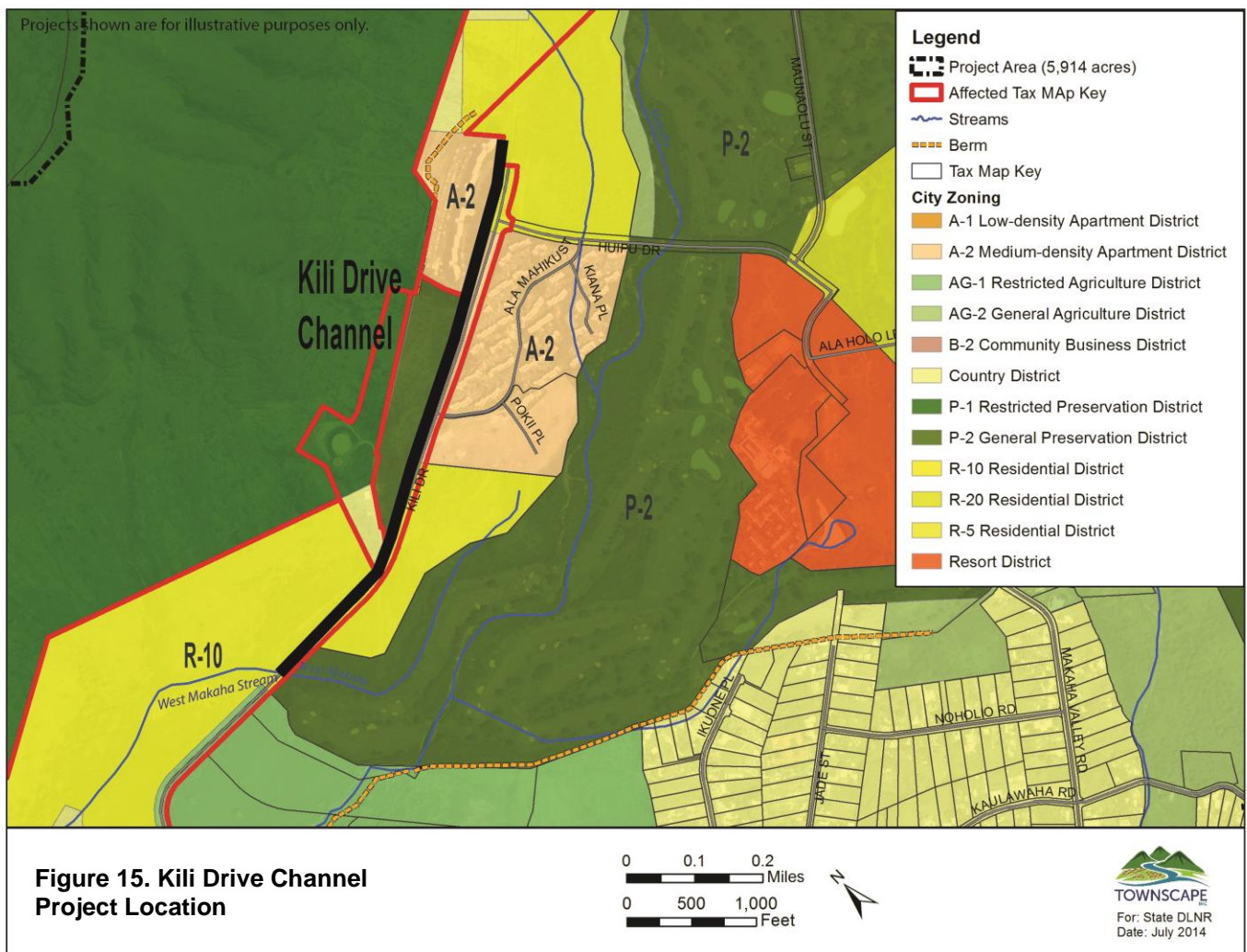

Pod trees fronting the entrance to the Mākaha Valley Towers complex. If removal of the trees will be an issue, an underground culvert system will need to be constructed in that area. However, use of an underground culvert system should be considered a last resort. The intent is to use Kili Drive as the maintenance road, therefore, an additional maintenance road is not needed. The useful life of this project is 50 years.

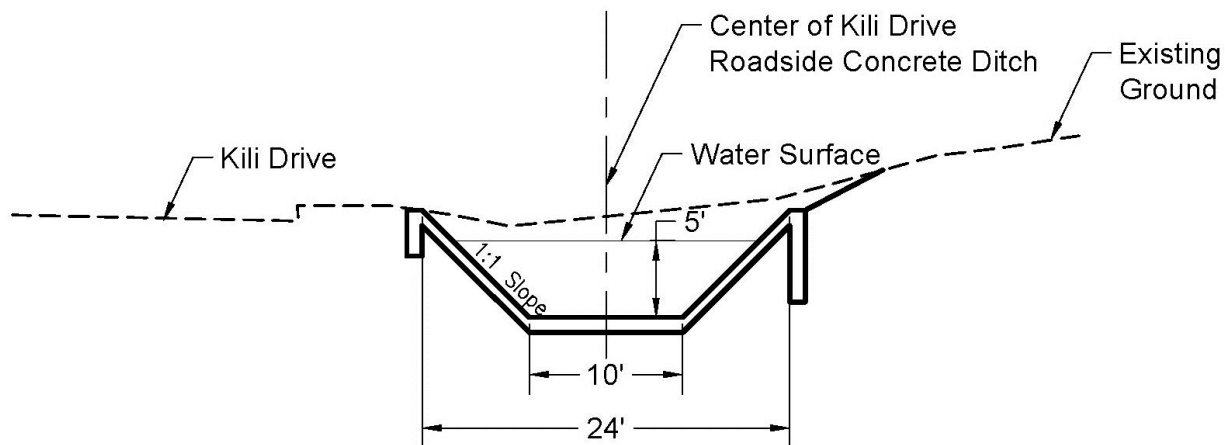

Kili Drive - Concrete Channel

Looking Makai

Implementing Entity

Board of Water Supply; HRT, Inc.; Mākaha Valley Towers

Ongoing Maintenance Entity

Board of Water Supply; HRT, Inc.; Mākaha Valley Towers

Estimated Project Cost

The estimated cost to construct the Kili Drive Channel is approximately \$12,937,000 to \$19,937,000. This estimated cost includes obtaining easements for four parcels (estimated value totaling \$937,000¹¹) from three different landowners. Based on the City's property information (as of July 2014), the landowners are Mākaha Valley Tower, HRT, Inc., and the City's BWS.

¹¹ Based on City's Assessed Values as of October 1, 2009. Easement values were estimated based on using a percentage of the assessed land value equivalent to the percentage of the total area required for the flood mitigation project for each parcel. Values are based on a 24-foot wide easement.

Cost Item	Estimated Cost
Acquisition	None
Easements	\$937,000 ^a
Environmental	\$500,000 - \$1,000,000
Survey and Design	\$1,000,000 - \$2,000,000
Construction Management	\$500,000 - \$1,000,000
Construction	\$10,000,000 - \$15,000,000
Total	\$12,937,000 - \$19,937,000

^a Based on City's Assessed Values as of October 1, 2009. Easement values were estimated based on using a percentage of the assessed land value equivalent to the percentage of the total area required for the flood mitigation project for each parcel. Values are based on a 24-foot wide easement.

Similar to the Eku Stream Channel, a less costly alternative to lining the channel with concrete is lining it with erosion control matting. Simply grading the channel and leaving it unprotected from erosion will not be in conformance with the DOH requirements. The City requires that flow velocities do not exceed five feet per second. If the channel were to be built with the dimensions provided for the concrete channel, but lined only with erosion control matting, the velocity would exceed the City's standards for channel velocities. Since the Kili Drive Channel would be privately-owned, the City would not have jurisdiction with regards to design standards. However, the State DLNR recommends following the City's standards. The estimated cost for the Kili Drive Channel with erosion control matting is approximately \$1,300,000 to \$1,500,000.

Storm Damages w/o the Project

Potential storm damages without the proposed Kili Drive Channel are:

- Road damages to Kili Drive
- Possible flooding of Mākaha Valley Plantations (a 572-condominium complex)
- Road damages to Huiipu Drive
- Possible flooding of Mākaha Oceanview Estates (residential community)

Benefits w/ the Project

The benefits of constructing the Kili Drive Channel are:

- Reduced flooding of Kili Drive that has turned the road into a river in past storms, which has closed Kili Drive due to hazardous driving conditions and resulted in significant road damages
- Reduced runoff discharged into Mākaha Stream by collecting runoff from behind Mākaha Valley Towers and from the BWS Reservoir Road and redirecting it to West Mākaha Stream that would otherwise be conveyed under Kili Drive, Mākaha Valley Plantations, Mākaha Oceanview Estates complex and into Mākaha Stream

7.1.7 Project No. 07: Mauna ‘Olu Estates Drainage Improvements

A separate study is being done by the BWS for the Mauna ‘Olu Estates Drainage. Sections of the existing system of ditches and berms, located on land owned by the BWS, above the Mauna ‘Olu Estates subdivision are not functioning as originally constructed.

The tributary area is divided into four areas ranging from 52 acres to 139 acres, with the total area slightly less than 400 acres. The TR-55 method was used to estimate peak flows for the 10-, 25-, 50-, and 100-year storms. A total of 2,776 cfs is generated during a 100-year storm event. Of this total, 1,264 cfs was intended by developers to go through the Mauna ‘Olu Estates via the existing ditch system running through the subdivision and into the Mākaha Stream. The remaining 1,509 cfs was intended by developers to be conveyed along the mauka boundary of Mauna ‘Olu Estates towards the golf course and flow into the Eku Stream. A total of 1,411 cfs, 1,945 cfs, and 2,356 cfs is generated during a 10-, 25-, and 50-year storm events respectively.

The BWS is in the process of investigating the type of proposed drainage improvements that would be needed, what impacts any improvements would have on various nearby cultural and historic resources in the valley and the estimated costs to construct the proposed improvements. Recommendations on how to convey the offsite drainage may include improving only certain problematic areas or improving the entire system with (1) possibly a new lined drainage ditch or levee walls and/or (2) the construction of detention basins at the mauka and makai ends of the existing berm and ditch system. Flow from one of the detention basins would be released as sheet flow onto the East Golf Course. The intent of the overall design is to maintain the tributaries to Eku and Mākaha Streams as described above.

The BWS plans to meet with the Mauna ‘Olu Estates Homeowners’ Association to discuss options for drainage improvements moving forward.



Existing ditch and berm above the Mauna ‘Olu Estates subdivision

7.1.8 Project No. 08: In-stream Detention Basins for Mākaha Stream

In-stream detention basins are often used in intermittent streams to reduce the overall impact of storm events to downstream areas. These detention basins will vary in size and number depending on the availability of area along the stream alignment.

The highest amount of runoff contributing to 70 percent of the peak flow for Mākaha Stream is from subarea 1 (as shown in **Figure 5**). This drainage area consists of forested lands owned by the BWS. Construction of several detention basins in Mākaha Stream is needed in order to retain and hold back some of the runoff in the valley.

For Mākaha Stream, at least two such basins should be constructed to reduce the impacts to the low lying populated area. Subareas 1 and 2 (tributary areas MA#1 and MA#2 from **Figure 5**) were chosen for basin locations mainly because they are large, mostly undeveloped, contribute the most runoff to the stream, and are largely independent of each other. However, these characteristics do not mean that the other subareas or tributaries cannot contain in-stream or off-line detention basins. Hydrologically and hydraulically speaking, the more detention basins, the better.

Since the peak flow of subarea 1 is drawn out over a longer period and does not overlap with the other drainage areas for Mākaha Stream, detention basins in subarea 1 and other subareas will be required to reduce the total peak flow value. Detention basins of approximately 6,550,000 cubic feet (about 7.5 acres by 20 feet deep) for subarea 1 and 2,250,000 cubic feet (about 2.6 acres by 20 feet deep) for subarea 2 will reduce the total peak flow to about 9,844 cfs, which is approximately a fifteen percent reduction. Possible locations for these detention basins include an area just mauka of Huipu Drive to the west of Mākaha Stream and in the mauka areas above Kāne'ākī Heiau on the BWS lands. However, the topography in the mauka areas may not be conducive to large detention basins. Relatively steep terrain would make both basin construction and ongoing maintenance difficult and expensive.

Breaking these basins up into smaller ones while maintaining the total detention volumes would be advisable to reduce the land impacts on any given land owner. However, more detention basins throughout the valley will require a higher level of maintenance effort because more basins will need to be inspected and cleaned. The total volumes recommended above are high. Reducing their sizes is possible but will result in less detention value. More detention basins of smaller capacity would be beneficial for the smaller sized storms. Exact locations for larger or smaller detention basins still need to be determined.

Detention basins should only be left unlined if the excavated material is solid rock. In most cases, basins are lined with larger river rock, gabion baskets, matting, or re-vegetated with stockpiled grubbed material. In all cases, government permits will require erosion control measures to minimize transport of exposed soil downstream during flows. Construction should occur in the dry months, which has historically been between May and October. Once constructed, all basins should be inspected after a storm event where flow in the stream is observed or at a minimum once a year if no flows have occurred. Material deposits from flows should be used to shore up eroded banks, weirs or be properly disposed of.

7.1.9 Project No. 09: Restore Mākaha Surfing Beach “Pond”

The USGS quadrangle map for “WAIANAE, HAWAII” (scale 1:24,000; 1983) shows a “depressional” 10-foot contour area at the Mākaha Surfing Beach. The depressional contour extends from the outlet of Mākaha Stream to the outlet of West Mākaha Stream, and is about 600 feet in length and about 150 feet in width = about 90,000 square feet = about 2 acres in area. Mākaha Surfing Beach in this area, from Farrington Highway to the waterline is about 300 to 350 feet in width, so this depression occupied about half of the width of the beach in this area.

Community members who are very familiar with conditions at Mākaha Surfing Beach say that there used to be a natural “pond” that extended from the outlet of Mākaha Stream to the outlet of West Mākaha Stream – more or less in the area that shows as a “depression” on the USGS map. These community members say that this “pond” functioned as a natural debris basin, catching and holding silt and debris from flooding of the streams and thus preventing this material from being deposited on the beach and in the near shore waters. After flood conditions abated, community members would clean out debris from the “pond.” The “pond” would also hold water for some days after a storm, and the Mākaha Beach folks would stage “races” here with small model boats and engage in other kinds of recreation.

After the destructive storm of 2008 City crews worked to “restore” Mākaha Surfing Beach. Unfortunately, according to beach users, the City crews mistakenly filled in most of the “pond” area during this beach reconstruction project. As a result of the City work, there is now an area of the beach about 50 feet in width that provides a “channel” for flood waters to flow from Mākaha Stream, between the highway and the beach berm, to the West Mākaha Stream outlet, from which point flood waters flow toward the ocean. However, this channel is not low enough to serve the debris catchment function of the original “pond” area.

A report was prepared by the University of Hawaii Sea Grant College Program for the City’s DPR and the State DLNR Office of Conservation and Coastal Lands (OCCL) in 2010. The report provided guidelines on

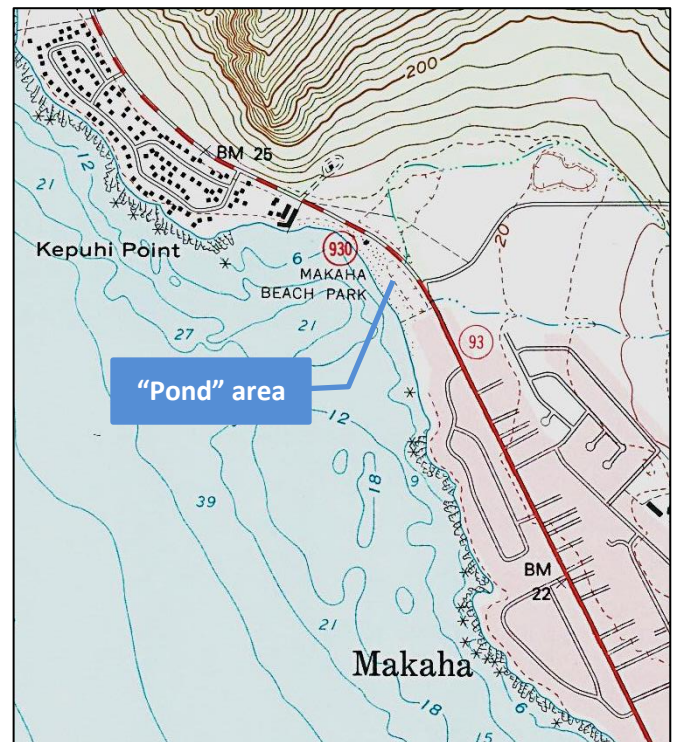

1983 USGS map showing “depressional” contour

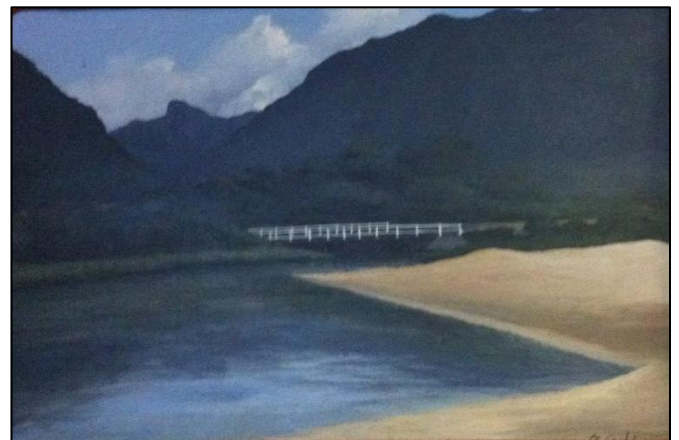

Painting of “Pond” area at Mākaha Beach

beach management for Mākaha Beach and should be used as guidelines for any future maintenance work for that area.

The Mākaha Surfing Beach “pond” should be restored – both to serve as a natural debris catchment feature and as a recreational amenity for beach users. The City (DPR) and the State (DLNR) have joint jurisdiction for the management of Mākaha Beach. The DLNR has jurisdiction for areas of the beach that are seaward of the certified shoreline, while the City has jurisdiction from the high watermark to the private property boundaries. As the “pond” area is above the high watermark, City maintenance personnel from the Department of Facilities Maintenance could do the work at the request of the City’s DPR. Clearances may be required from the USACE and from the State Department of Health (DOH) and the State DLNR OCCL. Since this work would be **corrective action** for an earlier beach reconstruction project, the full range of conservation and coastal permits may not be required. However, a National Pollutant Discharge Elimination System (NPDES) permit from the State DOH will be required if more than one acre of the beach, including both sand removal and sand placement, will be disturbed.

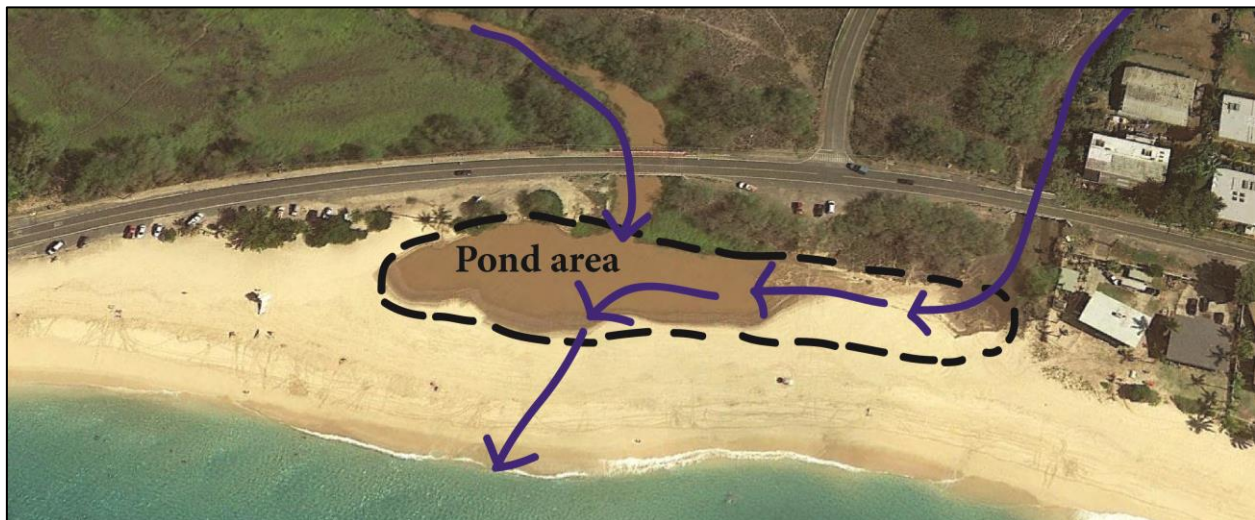

Illustration of recommended “Pond” area to be restored at Mākaha Beach

Implementing Entity

City and County of Honolulu, Department of Parks and Recreation

Ongoing Maintenance Entity

Honolulu Department of Facilities Maintenance

Estimated Project Cost

“Maintenance Project”; Cost for NPDES Permit

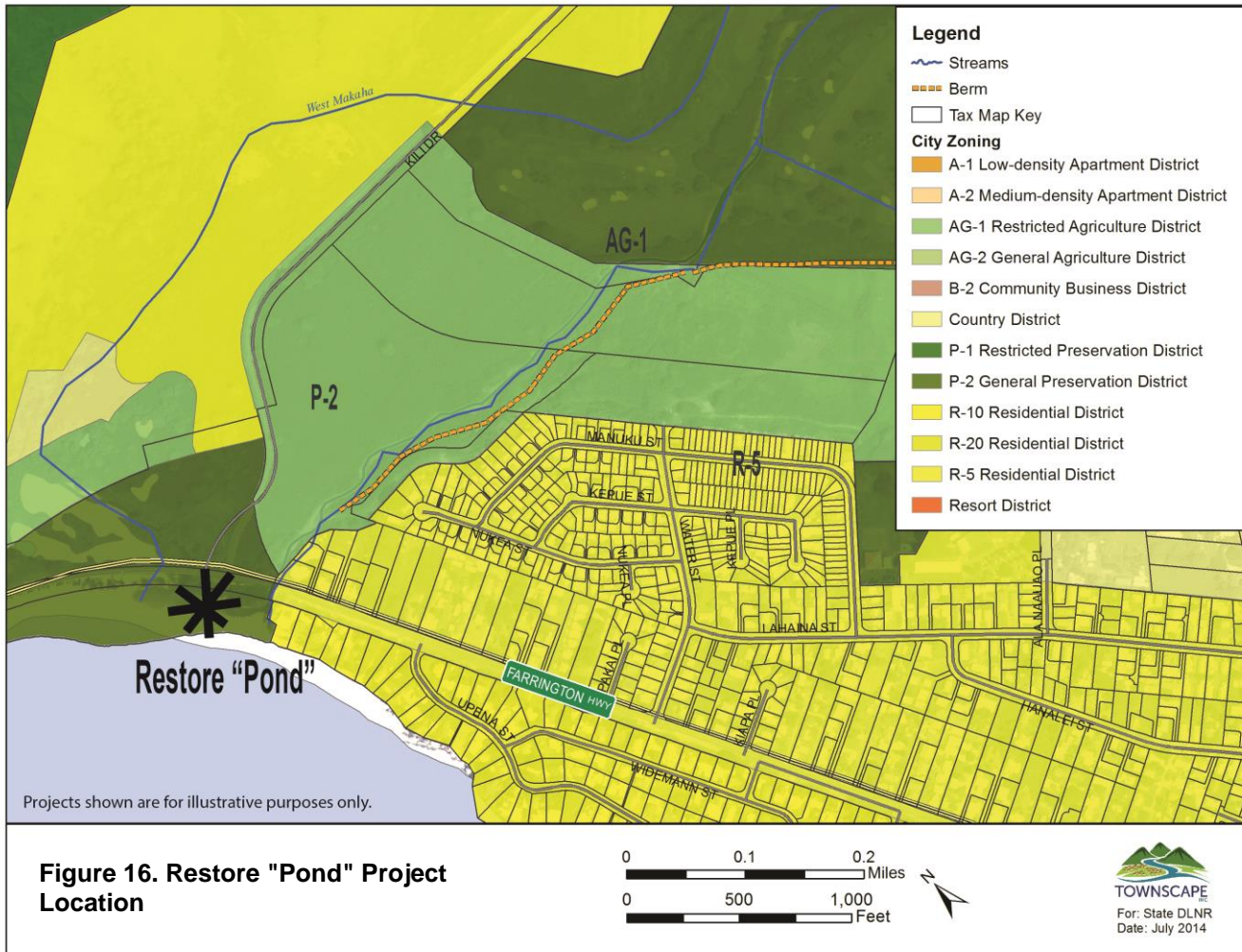

7.2 Nonstructural Measures

Nonstructural measures include ongoing programs that will help alleviate flooding in the valley.

The nonstructural programs recommended for Mākaha Valley are:

1. Watershed Restoration
2. Stream Channel Maintenance
3. Storm Drain Maintenance
4. Enforcement of existing legislation
5. Education on Best Management Practices for Watersheds
6. Drainage improvements required for future development

7.2.1 Watershed Restoration

In Hawai'i, watersheds are critically important—for water supply, water quality, air quality, natural habitats, scenic beauty, outdoor recreation and natural resource educational programs. They provide indirect services such as groundwater recharge by intercepting rainfall. Research shows that forest restoration can change soil hydraulic properties and that infiltration rates are two times greater in reforested areas compared to deforested areas¹². Most of our watersheds are critically endangered and have been overrun by feral pigs and goats and by nonnative and invasive plants. The degraded condition of our watersheds has resulted in a host of negative environmental consequences, including increased runoff and erosion, poor water quality for streams and near shore waters, siltation of near shore reefs, decreased water infiltration and lower yields from aquifers, lower base stream flows, and increased stream flooding.

The BWS owns nearly two-thirds of Mākaha Valley, which includes the majority of forested areas. The forested areas consist mostly of nonnative species such as strawberry guava and coffee. Improving the forests through native forest restoration will help to retain and absorb more water; thus reducing the peak amount of storm water that travels down the valley in the streams.

Watershed restoration is a long-range project that will focus on incremental fencing of areas of the upper watershed to exclude feral pigs and goats, removal of invasive plants, planting native



Forested areas in upper Mākaha Valley

¹² Perkins, K.S., J.R. Ninmo, and A.C. Medieros (2012). Effects of native forest restoration on soil hydraulic properties, Auwahi, Maui, Hawaiian Islands. *Geophys. Res. Lett.*

plants, restoration of traditional wet lo'i terraces and dry agricultural fields. The expected outcome after many years of these actions is the restoration of a healthy forest and a healthy watershed. In addition, recapturing storm water runoff through the use of “keyline swales” or small detention ponds will reduce some of the runoff from tributaries into the stream, allow water to infiltrate into the ground and can serve as a water source for the BWS firebreak vegetation.

The U.S. Army Garrison-Hawaii, in partnership with the BWS, has constructed exclusion fences on land owned by the BWS in the upper reaches of Mākaha Valley. About 120 acres of native plant habitat has been enclosed. The purpose of the fence is to keep out goats and pigs that pose a threat to the endangered species and native forest resources. The BWS has worked with the Wai‘anae Mountains Watershed Partnership to remove invasive species in Mākaha Valley. In the past, groups such as the Youth Conservation Corps have volunteered to help with clearing invasive plants. More volunteer groups’ involvement and community outreach are needed to support these forest restoration efforts.

Since most of the forested areas in the valley are owned by the BWS, significant commitment to forest restoration from the BWS is needed. Forest restoration will also require a significant amount of manual labor, some of which can be provided with the help of volunteers and forming partnerships with organizations, school groups, and community groups.

This recommended measure will provide long term benefits to the whole ecosystem. It will take many years to restore the watershed and many more years after that to observe significant improvement in reducing runoff.

A \$500,000 Grant-in-Aid was approved by the 2014 Hawai‘i State Legislature for forest restoration work in Mākaha Valley. Additionally, the BWS has committed to funding some of the forest restoration work.



Exclusion fence to protect native forest resources on the BWS land in the upper reaches of Mākaha Valley

7.2.2 Stream Channel Maintenance

While vegetation within the stream channel can help absorb some of the storm water and reduce the velocity of storm water traveling down the stream, overgrown vegetation, debris, and large trees reduce the carrying capacity of the stream. Fallen trees act as a dam—preventing the natural flow of storm water. As a result, storm water collects in an area, overtops the stream banks and floods nearby properties.

Keeping the channel clear of excess vegetation, removing debris and any obstructions either natural or dumped can help maintain the carrying capacity of the stream. Additionally, garbage and debris within the stream channel are carried off during large storms and discharged into the ocean, which negatively impacts the quality of near shore waters.

On O‘ahu, the responsibility for maintaining a stream rests with the owner of the stream [Revised Ordinances of Honolulu (ROH) 41-26.3]. Both Mākaha and Eku Streams are not owned by one entity, but ownership is shared by many private landowners. Most of the property lines in Mākaha extend to the centerline of the stream, which means that Mākaha Stream is owned by at least four different landowners and Eku Stream is owned by more than twenty different property owners.

Since the streams are privately owned, it is critical that property owners maintain the streambed by keeping it clear of excess vegetation and debris, as it is their responsibility to do so. Some community members have claimed that the majority of the flooding in 2008 near Eku Stream was caused by blockages in the stream. During a stream cleanup following the storm, bulky items such as mattresses were found in the streambed.

A State law (Act 76) allows the State Civil Defense (SCD) to enter onto private property to mitigate hazardous situations after giving the landowner notice and reasonable opportunity to mitigate the hazardous situation. The SCD has sent letters to property owners in the past to inform them of their responsibility to maintain their section of the stream.

While the City can enforce regulations requiring stream owners to maintain the stream, a Stream Channel Maintenance Program with regularly scheduled community-wide clean up dates would be more effective.

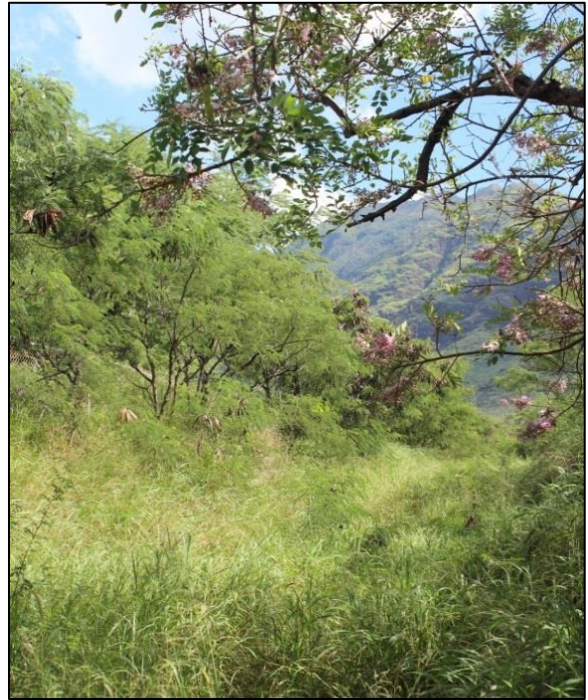

Overgrown vegetation in Eku Stream Channel facing mauka



Debris jam in Eku Stream after December 2008 storm

Maintaining the carrying capacity of the stream requires a coordinated effort amongst all property owners to maintain their section of the stream channel. A coordinating organization or government agency, such as a drainage district, may be able to assist landowners in maintaining their sections of the stream. Access into stream channels for maintenance may be a challenge since it requires getting permission from streamside property owners to enter into private property. Maintenance easements should be explored in exchange for a community stream channel maintenance program.

In the past, a stream cleanup was organized by Representative Jo Jordan in February 2012. More than 25 volunteers assisted with removing eight truckloads of green waste, six truckloads of rubbish, and one truckload of metal waste from Eku Stream. HRT, Inc., a major landowner of several large undeveloped parcels has in the past hired personnel to clean their sections of Mākaha Stream.



Community members help remove green waste during stream cleanup for Eku Stream in February 2012

Additionally, the City’s Department of Environmental Services Water Quality Branch sponsors the “Adopt-a-Stream” program, which is a volunteer program where participants commit to a minimum of four cleanups per year for two years. This program provides volunteers with supplies. Through this program, there are opportunities for school groups, businesses, organizations, and residents to Adopt Mākaha or Eku Streams. More information on the Adopt-a-Stream program can be found at <http://www.cleanwaterhonolulu.com/storm/hero/adopt.html>.

In addition to maintaining the stream channel, the stream mouth also needs to be maintained. A sand berm is located at the mouth of Mākaha Stream and effectively turns the beach into a large pond until the sand berm is breached by the stream or is mechanically opened by equipment operators. As a result of the sand berm, stream flows backwash into the stream and flood adjacent properties. A program to open up the beach berm may be necessary and should include at minimum a definition of what is to be done, who will perform this work, how it will be physically done, and how it will be funded.

At the request of the City's DPR, who has joint jurisdiction of Mākaha Beach with the State DLNR, the City's DFM can create channel openings at stream mouths. Clearances are required from the USACE and DOH prior to stream mouth openings. In the case of emergencies and for safety concerns, the DFM can open stream mouths and then later submit the proper documentation to USACE after opening the stream mouth. However, permits may not be required if local residents created a stream mouth opening by hand with shovels and buckets. Local folks at Nānākuli and Waimea Bay have organized their own efforts in the past.

The owner of the house on the beach adjacent to Mākaha Stream has claimed that creating a channel through the sand berm will cause erosion to their property. The opening needs to be located along the berm so that it does not cause erosion and so that it will allow the stream flow to freely discharge into the ocean.

ROH 41-26.3 states that the owner of a stream:

"...has the duty to maintain, dredge, and clear such stream so that the natural flow of water runs unimpaired. The owner shall also be responsible for the removal of any debris, vegetation, silt or other items or material of any kind that may interfere with the natural flow of water."



***Debris and litter
along West Mākaha Stream***

7.2.3 Storm Drain Maintenance

Small rocks and debris clog up the storm drains, particularly catch basins near Kili Drive during storms, which prevent the discharge of storm water. As a result, roads are flooded—leading to significant road damage. Storm drains need to be cleaned out regularly of silt and trash. Storm drain maintenance includes clearing out culverts that fill up with debris and trash, and large rocks that pile up behind debris poles at the mouth of a culvert (i.e. makai of Mākaha Valley Towers).

While storm drains on City-owned roads are maintained by the City, maintenance responsibility for storm drains located on privately-owned roads rests with the owner of the road. The City can enforce maintenance of privately-owned storm drains to ensure that storm water can enter freely into them.

However, regular storm drain maintenance for both City and privately owned roads is an issue due to budget constraints and manpower. “Adopt-a-Storm Drain” programs can be implemented for Mākaha Valley where volunteers take on the responsibility of removing debris from the storm drains. Cities such as the City of Superior in Wisconsin have successfully incorporated an Adopt-a-Storm Drain Program.



*Three-foot debris poles
filled with rocks to the top*

7.2.4 Enforcement

Enforcement of existing legislation that requires stream owners to maintain streams and waterways is a critical component in reducing flood risk. The City has the power to issue a Notice of Violation to the owner of any stream who has failed to maintain and clear the stream, which includes removing debris, vegetation, or silt. If the owner of the stream does not properly address the Notice of Violation to maintain and clear the stream within 30 days of the notice, the City is then authorized to perform the necessary maintenance and clearing of the stream and charge the owner of the stream for the costs of such work. Failure to pay the bill will result in placement of a lien on their property.

It is illegal to litter in any stream and violators can be served with a citation by the City (ROH Article 4, Chapter 29). Enforcing existing legislation of “no dumping” in the streams should help to maintain streambeds free of bulky items dumped by residents that impede the flow of water and contribute to water contamination as the items decompose.

7.2.5 Education on Best Management Practices for Watersheds

Many residents in Mākaha are eager to learn about and be involved in flood risk management. Residents have varying levels of knowledge about flood risks, with various kinds of information shared with other community members. While it is good that the community members share information, there is the potential to spread misinformation as well. At the first Mākaha Flood Study community meeting, several residents voiced the need for public education and to provide information on how to prevent flooding of their homes, including specific instructions on what to do. Residents shared their willingness to help reduce flood risk particularly for their property, but lack the guidance on HOW to do it. Residents seek information and guidance on floodplain management and what actions they can take NOW.

Bringing general awareness of the flooding issues to the community is also beneficial, including providing educational information on Best Management Practices (BMPs) to minimize flood risks.



Keiki helping during the community stream clean-up

Community involvement could include starting a standing FLOOD COMMITTEE within the community's Neighborhood Board. Through the FLOOD COMMITTEE, residents can strategize and organize flood risk educational programs such as researching best practices, developing educational programs at Mākaha Elementary School, and starting community programs. Other programs may include developing a Neighborhood Watch program for illegal stream dumping, stream cleaning maintenance, and providing an informational campaign on flood prevention.

7.2.6 Drainage improvements required for future development

Our hydrologic analysis for Mākaha Stream and Eku Stream indicated that there was only a small increase in the 100-year flood flows when comparing flows for “existing conditions” and flows for “full build-out” conditions. For both streams, the “full build-out” scenario assumed that all as yet undeveloped land in these watersheds with residential or resort zoning would be developed.

However, the impact of future development on the 100-year storm peak flows is not the only issue of concern. We must also consider the following issues:

- ANY FUTURE DEVELOPMENT of undeveloped parcels has the potential of impacting adjacent downstream properties with increased flood flows. City drainage standards only require new developments to design their on-site drainage systems for a 10-year storm. Unlike drainage standards of the Hawai'i County Department of Engineering, which require new developments to DETAIN ON-SITE ANY INCREASE IN RUNOFF UP TO AND INCLUDING THE RUNOFF FROM 100-YEAR STORM, City drainage standards allow a new development to discharge storm water from the property provided that downstream drainage systems can accommodate those increased flows. For Mākaha Valley, with its piecemeal and poorly maintained drainage systems, and with

its two main streams experiencing significant flooding for 25-, 50- and 100-year storms, there is little or no “capacity” for existing streams and drainage systems to accommodate increased flood flows from new developments.

Our conclusion: any future development of zoned/undeveloped parcels should include a combination of on-site storm runoff detention and improvement of downstream drainage systems to prevent any increase in flooding of downstream parcels. Further, the ongoing maintenance of any drainage improvements downstream from the new development should be the responsibility of the development company or of the home owners association or condominium association that maintains common facilities of the completed development.

- Recent conceptual plans developed by one of the major land owners in Mākaha Valley show future development for several parcels in the Eku Stream watershed that are currently zoned AG-2 (General Agriculture) and P-2 (General Preservation). Any future development of these parcels and of other parcels that are currently zoned AG-1 or AG-2 or P-2 should also include a combination of on-site storm runoff detention and improvement of downstream drainage systems to prevent any increase in flooding of downstream parcels. As with the zoned/undeveloped parcels, the ongoing maintenance of any drainage systems downstream from the new developments should be the responsibility of the development company or of the home owners association or condominium association that maintains common facilities of the completed development.

7.3 Other considerations

7.3.1 Stream erosion control

Sections of Mākaha and Eku stream banks are somewhat degraded in the lower reaches of the streams. One community resident pointed out a section of Mākaha Stream near Huipu Drive and east of the Mākaha Valley Plantations complex where the streambed has greatly expanded. Visual inspection of the stream in this area revealed that the carrying capacity of Mākaha Stream near Huipu Drive is adequate to contain flows during a large storm, but streambank erosion control is needed.

Measures such as streamside vegetation used to control stream bank erosion also can slow down storm water velocity and reduce the amount of sediments transported into the ocean. Rock riprap or gabions may also help stabilize the stream banks. This erosion problem also occurs for property owners on Manuku and Nukea Streets.



Large trees within Mākaha Stream and eroded stream banks (facing mauka from Huipu Drive)

7.3.2 Mākaha Stream Channel

Another possible flood mitigation project to address flooding in the lower reaches of Mākaha Stream is to construct a concrete-lined or gabion rock channel for the stream. A concrete-lined channel would need to be approximately 50 feet wide at the base, 75 feet wide at the top, 9.5 feet deep, and with side slopes of 1 to 1; whereas a gabion rock channel would need to be about 100 feet wide at the base, 125 feet wide at the top, ten feet deep, and with side slopes of 1 to 1. The entire length of the channel would run approximately 2,600 feet upstream from Farrington Highway to the damaged berm area. A 16-foot wide maintenance road is suggested, but may be eliminated if the channel is used as the maintenance access.

Project cost for the channel is estimated to be at least \$27 million in addition to obtaining easements to construct the channel. Less costly alternative to concrete-lined or gabion rock channel such as using erosion control matting would cost about \$12 to \$13 million. Similar to the Mākaha Stream levee, benefits of the channel include protecting residential properties up to the 100-year storm, avoided insurance costs, and increased property values of nearby parcels from reduced flood risk. In addition, development of a channel for Mākaha Stream will protect several large undeveloped parcels from flooding up to the 100-year storm since the proposed channel will “contain” the 100-year storm. However, due to the high cost of this channel compared to the benefits it would provide, development of a channel for Mākaha Stream was not included in the previous recommended structural projects.



*Existing Mākaha Stream Channel near Farrington Highway
(facing makai)*



*Lower reaches of Mākaha Stream Channel
overgrown with vegetation
(facing mauka)*

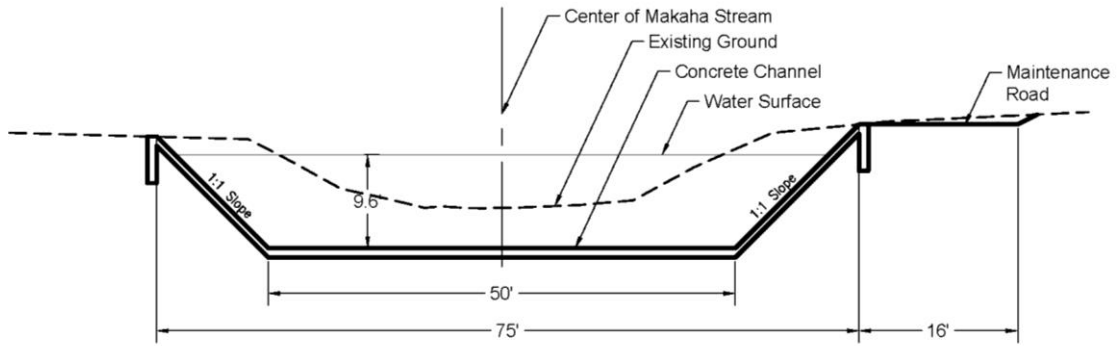

Makaha Stream - Concrete Channel

Looking Makai

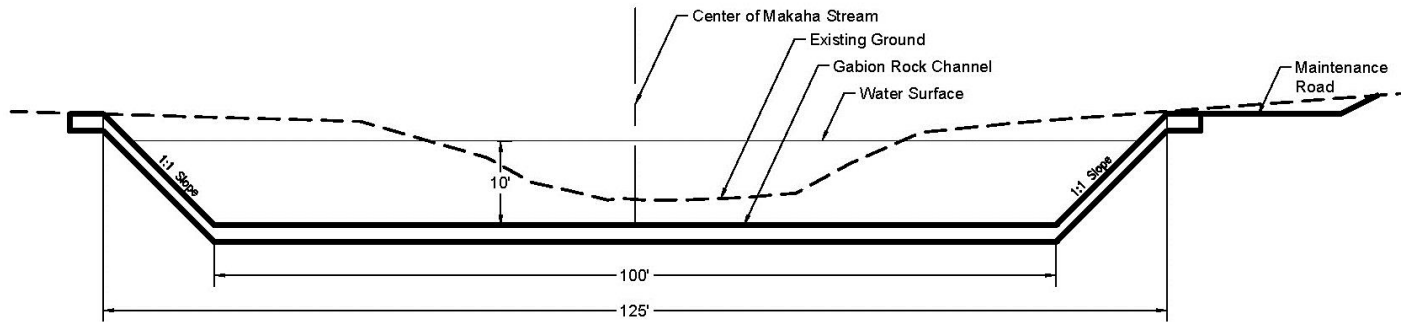

Makaha Stream - Gabion Rock Channel

Looking Makai

7.3.3 Farrington Highway, Replacement of Mākaha Bridges No. 3 and No.3 A

The State DOT is currently in the process of finalizing plans for replacing the two wooden bridges that convey the Mākaha and West Mākaha stream flows under Farrington Highway with two larger capacity concrete bridges. The design work for the bridges and related up-stream and down-stream improvements has been completed.

The existing bridges were found to be structurally deficient through bridge inspections conducted by the DOT. This evaluation was strictly for structural stability and not hydraulic adequacy. However, the DOT did conduct a hydrologic study to determine what the bridge hydraulic openings should be. The 100-year flood flows calculated for the DOT project were 9,185 cfs, which differs from the FEMA flow of 11,561 cfs. This difference was stated in a public meeting for the bridges.



*Existing wooden bridge for Mākaha Stream
along Farrington Highway
(facing makai)*

The detailed hydraulic study for this flood study ended approximately 150 feet upstream of Farrington Highway and does not tie into the DOT hydraulic calculations because of the difference in flow rates. The hydrologic study for this report yielded a flow of 11,413 cfs, which is comparable to the FEMA flow.

The combined hydraulic cross-sectional area of the planned new bridges is 1,295 square feet, which is 36 percent (or 950 square feet) more than that of the existing bridges. Theoretically, this cross-sectional area should handle the Mākaha Stream and West Mākaha stream flows. However, the Mākaha beach berm effectively turns the whole area into a large pond until the berm is breached by the stream or is mechanically opened by equipment operators. A program to open up the beach berm may be necessary and should include at minimum a definition of what is to be done, who will perform this work, how it will be physically done, and how it will be funded.

Some community members claim that the proposed bridge project should not move forward and that flooding of their properties will worsen with the current proposed plans. According to the construction plans by R.M. Towill Corporation, improvements will be done to upstream areas of Bridge 3 in Mākaha Stream. Improvements include riprap walls along Mākaha Stream: a 10-foot high wall approximately 120 feet upstream on the eastern side of Mākaha Stream and a 12-foot high wall on the western side of the stream. This Mākaha Valley Flood study recommends that the riprap walls be constructed to the same elevations. The riprap on the eastern side of the stream will tie into the recommended flood wall (Project No.05: Mākaha Stream Levee) for the stream. With the construction of both the proposed Mākaha Stream Levee and the riprap wall as a result of the bridge replacement project, homes in lower areas near Mākaha Stream will be protected from flooding, including from the 100-year flows.

7.3.4 Mākaha West Golf Course

Pacific Links Hawai'i is redesigning the Mākaha West Golf Course to a new 18-hole championship golf course. It is currently in the design and permitting phase of redeveloping the golf course, which is currently not open for play or in playable condition. Community members are concerned that the redesign of the golf course will lead to increased flooding in the valley. The engineers for the new golf course design have indicated that the new golf course will not increase runoff from the property.

According to the construction drawings dated May 30, 2014 by Wilson Okamoto Corporation, the existing golf course grades will be modified by filling or cutting within the FEMA published 100 and 500-year flood zones. Work will include grubbing of existing vegetation and grading for new golf holes. However, all proposed work occurs within the golf course property. The hydraulic analysis using the proposed grades reportedly does not increase the flood zone limits outside the golf course property. Also, the proposed flood zone limits reportedly tie back into the published base flood elevations within two cross sections below the golf course development. The hydrology remains the same within the proposed development because of the similar surface characteristics and the addition of detention basins. Pacific Links Hawai'i applied for a Conditional Map of Letter Revision (CLOMR) in September 2012 and received approval from the FEMA on November 21, 2013. A Letter of Map Revision (LOMR) will be applied for after construction is completed and verification that the new grades are in accordance with those represented in the CLOMR. Upon approving the LOMR, the FEMA will publish the revised FIRM and associated stream profile and data using the maps and information developed in the CLOMR.



Existing Mākaha West Golf Course to be redesigned into a new 18-hole championship golf course

7.3.5 Farrington Highway Realignment

The City and County of Honolulu developed a master plan (**Figure 17**) for Mākaha Beach Park in 1996. The master plan included development of picnic areas, a new multi-purpose field, renovations to existing facilities, and realignment of the existing Farrington Highway to a mauka alignment.

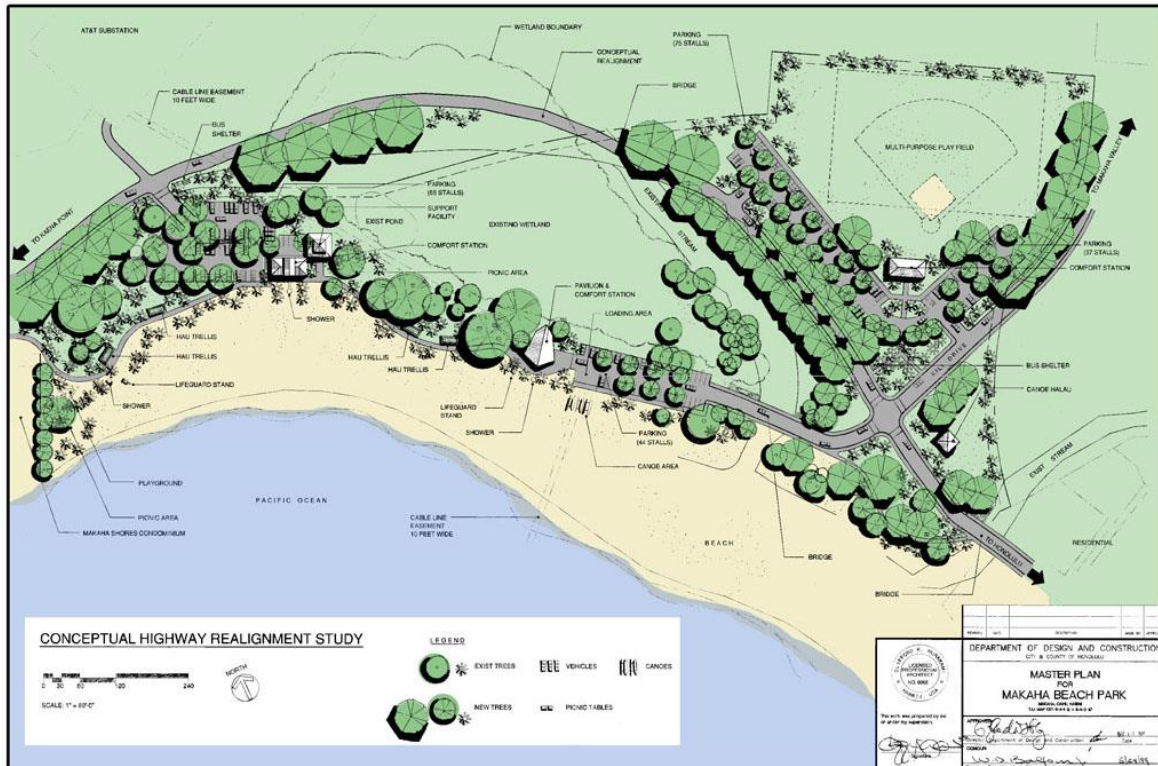

Figure 17. Mākaha Beach Park Master Plan (1996)

Some community members are concerned with the safety of park users due to the existing location of the road as it runs between the beach and the public facilities. Farrington Highway is also continuously threatened by the high surf. In addition to the public safety concern with park users and pedestrians crossing the highway, Mākaha Beach and Farrington Highway could become inaccessible due to beach erosion and wave damage. Community members suggest that realigning the highway to a mauka alignment would also restore the natural wetlands and bring back the natural fish pond that used to be there.

While the master plan would address public safety concerns for park users, it is critical that it also account for potential flooding issues with the proposed realignment of the highway. In addition to the two existing bridges on Farrington Highway, another bridge will be needed mauka of the existing Farrington Highway at the proposed realigned road with hydraulic capacities that can convey the 100-year flows. The O‘ahu Metropolitan Planning Organization (OMPO) plans to fund a feasibility study for the relocation of Farrington Highway near Mākaha Beach Park in the next fiscal year.

7.4 Maintenance Tasks and Costs

Ongoing maintenance of drainage infrastructure is important to prevent flooding previously experienced by residents in Mākaha Valley. Community members have shared that debris in stream channels and clogging of storm drains contributed to flooding of Mākaha Valley during past rain events. Acquiring funds to implement some of the recommended drainage improvements will be challenging due to the high costs. However, maintenance of stream channels, existing and recommended structures may alleviate a significant amount of the flooding.

Maintenance of the existing structures should include the following:

- a. Delineate easements around the existing structures
- b. Define “maintenance of existing structures” or standard of care (such as area to maintain, access, maneuvering area, removal of structures)
- c. Convey easements to the community association (or some group/agency) that will be the deciding body that procures the maintenance contractor
- d. Procure a maintenance contract
- e. Contractor works to bring existing structures to a standard of care then begin maintenance work

Once the standard of care is reached, the contractor should:

- a. Continue maintaining the structures
- b. Repair the breach in the berm using gabion baskets
- c. Maintain the Mākaha Stream berm (such as widening the narrow parts, inspecting the berm after storm events and repair if needed)
- d. Widen Eku Stream if it is narrower than what it used to be historically
- e. Enlarge the Mākaha Beach pond
- f. Open the sand berm at the mouth of Mākaha Stream before imminent storm events

The estimated cost for the aforementioned maintenance tasks ranges between \$400,000 and \$600,000 per year, which includes maintenance of the recommended projects proposed by this study.

Maintenance costs are anticipated to be on the lower end of the range with the proposed lined channels and maintenance roads. However, without these improvements, maintenance costs are anticipated to be on the higher end of the range since it will require more grass cutting, tree trimming, and bush wacking. Use of erosion control matting for streams will also require more maintenance; therefore resulting in higher maintenance costs as well.

A challenge is that there is no single entity to assume the responsibility of maintaining the various drainage structures that are scattered throughout Mākaha Valley. Major landowners and homeowners’ associations such as the BWS, Pacific Links Hawai’i, HRT, Inc., Mākaha Valley Towers, Mākaha Plantation, and Mauna ‘Olu Estates, may be able to help with funding some of the maintenance costs.

8. Prioritization of Structural Projects

Mākaha Valley flood mitigation projects were grouped based on feasibility of implementation. Projects with relatively low cost and high implementation likelihood, or with large benefits relative to their cost were categorized as Group 1. More complex and costly projects were included in Group 2. Additional projects with high initial cost relative to their benefits are listed in Group 3. Benefits were considered based on the following criteria: (1) public safety, (2) property and (3) infrastructure.

Table 8. Prioritization of Projects

Group 1	Group 2	Group 3
<ul style="list-style-type: none"> • Repair the breach in the Mākaha Stream berm • Restore Mākaha Surfing Beach “Pond” • Eku Stream Channel and Off-line Detention Basin 	<ul style="list-style-type: none"> • Mākaha Stream Levee • New Eku Stream Bridge at Farrington Highway 	<ul style="list-style-type: none"> • Kili Drive Channel • In-stream Detention Basins for Mākaha Stream • Noholio Road Drain Line

Two of the projects in Group 1 are considered “quick fixes”: repairing the breach in the Mākaha Stream berm and restoring the “pond” at Mākaha Beach. Repairing the breach in the Mākaha Stream berm is the least costly of the alternatives available to mitigate flooding for homes near Manuku and Nukea Streets. As noted earlier, this mitigation measure would only be a temporary solution to reducing flood risk for homes in this area until another breach occurs along the berm. Constructing a levee (listed under Group 2) would be a longer-term, but relatively costly, solution to this flooding problem. Another option, the most expensive of the measures mentioned above, is to channelize Mākaha Stream. A Mākaha Stream Channel is not included in a priority group because of low implementation likelihood due to the high costs associated with the project. The other “quick fix” project in Group 1 is restoring the



Stormwater near the “pond” area at Mākaha Beach

“pond” at Mākaha Beach. This project would also mitigate some of the flooding problems that impact residents in the lower reaches of Mākaha Stream. The Eku Stream Channel and Off-Line Detention Basin project would provide the most significant benefits, particularly for the well-being of residents near Eku Stream, and provide the highest amount of flood damage avoidance and flood insurance cost avoidance. The Eku Stream Channel could be built in phases; with the lower reaches of the channel built first, then constructing the remaining half of the channel, and finally the detention basin.

Projects in Group 2 are more complex and costly. As mentioned above, the Mākaha Stream Levee would be a longer-term solution to the flooding problem experienced by residents near Manuku and Nukea Streets. Without a new Eku Stream bridge with adequate capacity for 100-year flows, storm water will be constricted at the bridge.

Projects in Group 3 are projects that are recommended to mitigate flooding problems in the valley, but that have a high cost relative to the potential benefits, or lower likelihood of implementation. The Kili Drive Channel would probably have highest priority within Group 3 because the channel would capture a significant amount of the runoff from behind Mākaha Valley Towers complex. The runoff also goes through the Mākaha Valley Plantation complex—which could potentially affect many people and extensive property. The Noholio Road Drain Line is included in Group 3 because it requires the lower half of the Eku Stream Channel to be built first. Without improvements done to the Eku Stream channel, runoff from Noholio Road conveyed to Eku Stream could be a detriment to properties near Eku Stream.



Existing channel behind Mākaha Valley Towers

9. Summary of Environmental Impacts

This section provides a summary of environmental impacts of the proposed flood mitigation projects, and discusses potential regulatory constraints and requirements. A more detailed environmental impact assessment is included in Volume II of this report. The purpose of the assessment included in Volume II is to identify and evaluate potential impacts, including unintended effects in addition to the desired and intended effects, on the natural, socio-economic, cultural, and archaeological environment, that may result from proposed flood mitigation projects and measures for Mākaha Valley.



Stormwater flowing behind homes on Manuku Street during December 2008 storm

The proposed flood mitigation projects are generally consistent with the State and City designations for the land. No changes in land use will occur as a result of the proposed mitigation projects. Proposed projects will benefit public health and safety in terms of mitigating flood hazards. At least 50 residential units and business parcels would be protected from the 100-year storm with the proposed Eku Stream Channel, Off-line Detention Basin, and New Eku Stream Bridge. The proposed Kili Drive Channel would reduce the amount of runoff discharged into Mākaha Stream and the Mākaha Stream Levee would protect homes and several undeveloped parcels from the 100-year storm. While the proposed Mākaha Stream Levee would protect some homes from flooding, it may also unintentionally increase flooding on undeveloped properties located on the opposite side of the stream and levee.

While the proposed projects would prevent flooding of properties, the structural measures may accelerate the velocity of runoff and reduce sedimentation of floodplain areas before discharging into the ocean. Potential construction related impacts include discharge of construction materials into the stream and storm water runoff that mixes with sediments and construction materials.

Most of the projects proposed in this report will require government issued permits, which include the following:

- **Conservation District Use Permit (CDUP):** Any construction on conservation lands will require a CDUP from the DLNR (Chapter 183C HRS; Chapter 13-5 HAR). Exclusion fencing for native forest restoration on the BWS lands will require a CDUP.
- **Grading Permit:** If a project disturbs 50 cubic yards or more, the City will require a grading permit. All projects proposed in this report will require earthwork of more than 50 cubic yards. This permit is administered by the City's Department of Planning and Permitting (DPP) in accordance with Chapter 14 ROH 1990, as amended.
- **Letter of Map Revision (LOMR):** If construction in a FEMA flood zone will alter the flood zone, a LOMR will be required. The LOMR is administered by the City's DPP and is approved by the FEMA.
- **National Pollution Discharge Elimination System (NPDES) Permit:** A NPDES permit is required for any construction activity that disturbs more than one acre of total land area (HAR Chapter

11-55). The channel and levee projects will require this permit. The permit exists to protect properties adjacent to the project area from the discharge of construction waste and soil pollution during rainfall events. Pursuant to Section 402 of the CWA, the State DOH Clean Water Branch regulates discharge of pollutants into surface waters and administers this permit in accordance with Chapter 174C HRS and Chapter 13-169 HAR.

- **Special Management Area (SMA) permit:** Construction of projects within the SMA may require a permit. This permit is administered by the City’s DPP in accordance with Chapter 25 ROH 1990, as amended.
- **Stream Channel Alteration Permit (SCAP):** If a stream is determined to have beneficial in-stream uses of water, a SCAP may be required to alter a stream’s geometry. It is required for any temporary or permanent activity within a stream bed or banks that may (1) obstruct, diminish, destroy, modify, relocate a stream channel; (2) change the direction of the flow of water in a stream channel; or (3) remove any material or structure from a stream channel. The State DLNR Commission on Water Resource Management administers this permit in accordance to Chapter 174C HRS; Chapters 13-169 HAR.
- **Work within the State Right-of-Way:** Any work done within the Farrington Highway right-of-way will require this permit. The Mākaha Stream, Eku Stream, and Levee projects will require this permit. It is administered by the State DOT Highways Division in accordance with Chapter 127 of the HAR.

Construction of proposed flood mitigation projects will require a more in-depth analysis of archaeological sites within the project area. The analysis should include identifying areas that may not have been previously surveyed. An Archaeological Inventory Survey may need to be undertaken for one or more of the proposed projects. An Environmental Assessment (EA) or Environmental Impact Statement (EIS) will be required for any proposed flood mitigation project that may be funded through State funds.



View of Mākaha Valley from Mauna ‘Olu Estates subdivision

10. Next Steps

IMPLEMENTATION of the flood mitigation projects presented in this Flood Study will be challenging. Difficulties include:

- Most of the flood mitigation projects are located on privately-owned land. State and City agencies will typically NOT fund and implement projects that are located on privately-owned land.
- CIP funding from the Hawaii State Legislature and/or from Federal programs may be a possibility. However, most of the proposed flood mitigation projects will require significant capital funds – in the range of \$15 to \$30+ Million, and every year there are many competing projects that the Legislature and Federal agencies must consider.
- Given the high cost of fully engineered flood mitigation projects, less costly materials could be used—but maintenance costs would then increase.
- Ongoing maintenance of any flood mitigation projects like flood channels or levees will be another challenge. The maintenance of flood mitigation projects is typically performed by the City’s Department of Facilities Management (DFM), but the City will not assume the responsibility of maintaining facilities on privately-owned land.
- One or more of the major land owners or home owners’ associations may be able to implement and maintain flood mitigation projects in Mākaha Valley, perhaps with some assistance from public entities. As presented earlier in this Plan, any future development of land within Mākaha Valley should be conditioned with requirements for improvements of the overall drainage systems for Mākaha.

Most of the flood mitigation projects presented in this plan can be phased, and this strategy may mitigate some of the funding difficulties. For example, the Eku Stream channel and detention basin could be phased in 3 or 4 or more phases, with Phase 1 starting at Farrington Highway.

Overall, it will be critical for land owners, community groups, concerned citizens, elected officials and public agencies to continue to work together to implement flood mitigation projects to protect the health and safety of the Mākaha community.